

B18VAS2
802766

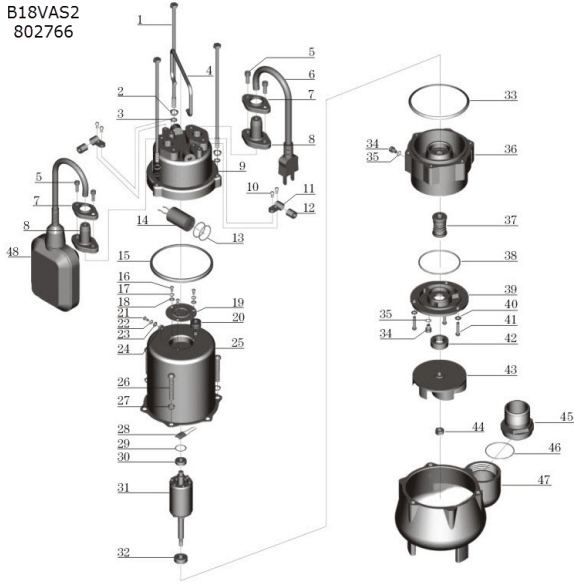

N0	DESCRIPTION	MATERIAL	N0.	DESCRIPTION	MATERIAL	
1.	Bolt	11	25.	Motor stator	11	
2.	Stretching washer	11	26.	Screw	11	
3.	Washer	11	27.	Stretching washer	11	
4.	Handle	11	28.	Thermal protector		
5.	Screw	11	29.	Undulated washer	1566	
6.	805706	Cable	30.	805724	Ball bearing	
7.	805708	Flange	11	31.	Rotor	
8.	805709	Cable protector	CR	32.	805723	Ball bearing
9.	Capacitor cover	No35B	33.	805721	Rubber washer	NBR
10.	Screw	11	34.	Screw	11	
11.	Cable presser	11	35.	"O" ring	NBR	
12.	Protector	NR	36.	Connection part	No35B	
13.	"O" ring	NBR	37.	805717	Mechanical seal	Alumina/Graphite
14.	805730	Capacitor	38.	"O" ring	NBR	
15.	805727	Rubber washer	NBR	39.	Oil chamber cover	No35B
16.	Screw	Fe360A	40.	Washer	11	
17.	Stretching washer	1566	41.	Screw	11	
18.	Washer	Fe360A	42.	805715	Oil seal	
19.	Press plate	Fe360A	43.	805712	Impeller	PA66/30% Fiber
20.	Line protector	NBR	44.	Nut	11	
21.	Screw	CuZn40	45.	Out-let connector	ABS	
22.	Stretching washer	1566	46.	"O" ring	NBR	
23.	Washer	CuZn40	47.	Pump body	No35B	
24.	Nut	11	48.	805705	Float switch	