

# GENIX VT

INSTRUCTIONS FOR INSTALLATION AND MAINTENANCE

**INDEX**

Key .....	2
Warnings .....	2
Responsibility .....	3
General description .....	3
1. Applications .....	3
2. Pumped liquids .....	3
3. Installation .....	3
4. Electrical connection .....	4
5. Accessories .....	4
6. Maintenance .....	4
6.1 Adjustment of run time .....	4
6.2 Maintenance instructions .....	4
7. Technical data .....	5
8. Management .....	5
8.1 Storage .....	5
8.2 Transport .....	6
8.3 Weight .....	6
9. Modifications and spare parts .....	6
10. Disposal .....	6
11. Troubleshooting .....	7

**KEY**

The following symbols have been used in the discussion:

**SITUATION OF GENERAL DANGER.**

Failure to respect the instructions that follow may cause harm to persons and property.

**WARNINGS**

Read this documentation carefully before installation.

Installation and operation must comply with the local safety regulations in force in the country in which the product is installed. Everything must be done in a workmanlike manner.

Failure to respect the safety regulations not only causes risk to personal safety and damage to the equipment, but invalidates every right to assistance under guarantee.

Skilled personnel



It is advisable that installation be carried out by competent, skilled personnel in possession of the technical qualifications required by the specific legislation in force.

The term skilled personnel means persons whose training, experience and instruction, as well as their knowledge of the respective standards and requirements for accident prevention and working conditions, have been approved by the person in charge of plant safety, authorizing them to perform all the necessary activities, during which they are able to recognize and avoid all dangers.

(Definition for technical personnel IEC 364)

The appliance may be used by children over 8 years old and by persons with reduced physical, sensory or mental capacities, or who lack experience or knowledge, on condition that they are under supervision or after they have received instructions concerning the safe use of the appliance and the understanding of the dangers involved. Children must not play with the appliance. Cleaning and maintenance intended to be carried out by the user must not be performed by children without supervision.

**Safety**

Use is allowed only if the electric system is in possession of safety precautions in accordance with the regulations in force in the country where the product is installed. (for Italy CEI 64/2)



The power supply cable must never be used to carry or shift the pump.



Never pull on the cable to detach the plug from the socket.



If the power cable is damaged, it must be replaced by the manufacturer or by their authorised technical assistance service, so as to avoid any risk.

Failure to observe the warnings may create situations of risk for persons or property and will void the product guarantee.

**RESPONSIBILITY**

**The Manufacturer does not vouch for correct operation of the electropumps or answer for any damage that they may cause if they have been tampered with, modified and/or run outside the recommended work range or in contrast with other indications given in this manual.**

**The Manufacturer declines all responsibility for possible errors in this instructions manual, if due to misprints or errors in copying. The Manufacturer reserves the right to make any modifications to products that it may consider necessary or useful, without affecting their essential characteristics**

**GENERAL DESCRIPTION**

Genix VT systems are compact small automatic lifting stations, suitable for pumping domestic waste water, where evacuation by gravity is not possible.

The utilities connected to this system can be used normally and require minimum maintenance.

The system will operate automatically as soon as the required level of water enters the tank.

**1. APPLICATIONS**

Genix systems are indicated exclusively for the treatment of domestic waste water from sinks, bathtubs, showers, or from washing machines and dishwashers.

The product must be fastened to the floor to prevent uplift and turning.

**2. PUMPED LIQUIDS**

The product is only suitable for pumping wastewater from a cabinet shower, bidet and dishwashers. Not for heavy-duty public, commercial or industrial use, and only for a limited number of users.

Any damage due to foreign bodies (wet wipes, food, cotton wool, tampons, hair, cotton cloths, wood, metal or plastic objects) or due to pumping liquids such as solvents, strong chemical agents and oil will not be covered by the guarantee.

Ordinary liquids for cleaning of the appliances connected. pH value: 4-10.

Maximum using temperature 90°C (for 30 min)



The product is sized for a maximum volume of 10 l litres and a maximum inlet of 130 l/min.

**3. INSTALLATION**

The system must never be lifted by its power cable to carry it. The product must be accessible for maintenance and repair. The product must be placed in a frost-free room to prevent the pumped liquid from freezing.



Make sure that all external pipework is adequately insulated. The discharge pipe must be made of rigid material, such as copper, or of rigid PVC with solvent-welded joints. To prevent the transmission of vibrations to buildings, make sure that the pipework is thoroughly fixed and that fittings cannot move and are not in contact with building parts.

Make sure to affix the “WaterMark” and “Prohibited items” stickers in a clearly visible location on the device.



**Installation in accordance with Plumbing Code of Australia and AS/NZS3500.**

#### 4. ELECTRICAL CONNECTION



Make sure that the product is suitable for the supply voltage and frequency available at the installation site. The electrical connection must be carried out in accordance with local regulations.



The product must be earthed.



The installation must include an earth leakage circuit breaker for protection against earth fault currents. This ensures protection when using a Schuko plug or another plug with earth pin. The product must be connected to a mains switch with a minimum contact gap of 3 mm in all poles. In case of overtemperature, a thermal switch cuts out the motor and cuts it in automatically when it has cooled sufficiently.

#### 5. ACCESSORIES

1- An alarm device for acoustic alarm in case of malfunction or high level in the tank is available as an accessory (noise level 75 dB(A)). Product number: 60166477.

2- A kit containing: a hose (length 500mm) with adapter, available as an accessory. Product code 60168126

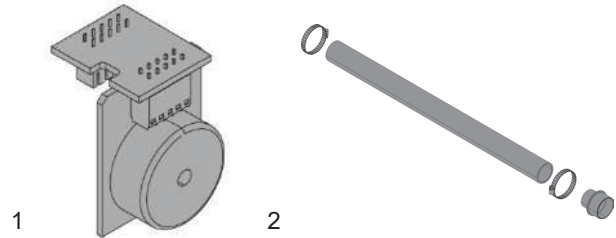

## 6. MAINTENANCE

The system does not require any particular maintenance, but we recommend checking the operation and couplings of the pipes at least once a year.

### 6.1 Adjustment of run time

The default setting ensures proper operation in most pipework. If the pipework is particularly long or short, it may be necessary to adjust the run time.

### 6.2 Service instructions

Thanks to the product design, service is easy in case of malfunction or blocked pump. Digits in the following sections refer to the pictures in the appendix “Troubleshooting”.



Before carrying out any service work, remove the fuse, pull out the plug, or switch off the power supply. Make sure that the power supply cannot be accidentally switched on. All rotating parts must have stopped moving. The product must only be serviced by trained service personnel.

### Impeller stuck

1. Disconnect the power supply
2. Remove the motor cover cap.
3. Insert a screwdriver (min. 110 mm) through the plug hole and into the slot of the shaft end. Turn the shaft right and left to free the impeller from dirt.

**Operation by means of a power drill**

1. Disconnect the power supply
2. If the product cannot be operated by electrical power, the toilet and system can be emptied by means of a power drill.

**Pressure switch pipe clogged**

1. Disconnect the power supply
2. Unscrew the screw of the motor cover and remove the cover
3. If the water level is above the motor flange, empty the tank by means of the appropriate tap and the hose (supplied).
4. Unscrew the screws of the board holder.
5. Remove the pressure switch pipe.
6. Clean the rubber hose and check the opening on the tank.

**Foreign body in tank**

1. Disconnect the power supply
2. Unscrew the screw of the motor cover and remove the cover
3. If the water level is above the motor flange, empty the tank by means of the appropriate tap and the hose (supplied).
4. Unscrew the side screw of the motor ring
5. Lift the motor flange to reduce the compression of the O-ring. Insert a screwdriver into the notch underneath the supply cable and press it down.
6. Extract the complete motor unit by means of the handles (lift the unit vertically before tilting it).
7. Check and clean the tank and impeller/grinder.

**Carbon filter**

1. Remove the filter cover
2. Replace the filter

**The carbon filter should be replaced once a year to ensure sufficient filter function.**

**Instead of using the activated carbon filter, the system can also vent through a vent pipe with diameter 20.**

**7. TECHNICAL DATA**

Model	Hz	Volt (V)	P1 (W)	Amp (A)	Cos φ	Hmax pump (m)	Flow max (m3/h)
Genix VT	50	220-240	530	2.5	0.95 0.91	8.0	7.8

- **Supply voltage:** see electrical data plate
- **Maximum operating pressure:** 90 kPa / 0.9 bar / 13 psi
- **Grade of motor protection:** IP44
- **Protection rating:** F
- **Noise level:** <70dB(A) to EN 12050-3
- **Delayed line fuses (version 220-240v):** indicative values (Ampere)
- **Duty:** S3 -50% 1min. (30 sec on; 30 sec off).
- **Ambient temperature:** da +5°C a +35°C
- **Start and stop levels:**
  - Start: 72 mm above bottom
  - Stop: 52 mm above bottom

**The system pressure should not exceed 6 m head to guarantee a sufficient drain of the connected sanitary appliances (see rapid guide).**

- **Storage temperature:** -10°C +40°C
- **Marking:**

**8. MANAGEMENT****8.1 Storage**

All the pumps must be stored in a dry covered place, with possible constant air humidity, free from vibrations and dust. They are supplied in their original pack in which they must remain until the time of installation.

## 8.2 Transport

Avoid subjecting the products to needless impacts and collisions.

## 8.3 Weight

The adhesive plate on the packaging indicates the total weight of the pump

## 9. MODIFICATIONS AND SPARE PARTS



Any modification made without prior authorisation relieves the manufacturer of all responsibility. All the spare parts used in repairs must be authentic and all accessories must be authorised by the manufacturer, in order to ensure maximum safety of the machines and of the systems in which they may be installed.



If the power supply cable of this appliance is damaged, the repair must be carried out by specialised personnel to prevent all risks.

## 10. DISPOSAL

This product or its parts must be disposed of in an environment-friendly manner and in compliance with the local regulations concerning the environment; use public or private local waste collection systems.

## 11. TROUBLESHOOTING

FAULTS		CHECKS (possible causes)	REMEDIES
1	The motor does not start and does not produce noise when the starting level is reached in the tank.	A. Supply failure. B. Check the protection fuses. (if also the new fuse burns out, either the cable or the motor is faulty). C. Blocked impeller. (the thermal switch is off). D. Pressure switch pipe blocked.	A. Reestablish the power supply. B. Replace the fuse. Measure cable and motor. If cable or motor is defective, replace the defective parts. C. Free the impeller, and wait until the motor is cooled down and the thermal switch has reset. D. Remove the pressure switch pipe and clean the pipe.
2	Motor hums but does not operate.	A. Impeller stuck. B. Motor or capacitor defective. C. Control board defective.	A. Free the impeller and check that it can rotate freely. B. Replace the motor or capacitor. C. Replace the control board.
3	The motor works continuously or starts at regular intervals.	A. Water leaking from inlet into tank. B. Water leaking back into tank from discharge pipe. C. Pressure switch defective. D. Excess foam.	A. Check for leaking appliances. B. Check the non-return flap. C. Replace the pressure switch unit. D. Check the air vent/ Check that the basin is connected to the top connection / Provide an air vent (See Quick Guide).
4	Motor runs but does not evacuate water.	A. Pump or tank blocked. B. Air lock in pump or vent hole in pump housing blocked.	A. Remove blockage. B. Check operation of vent valve in the tank. Check that the carbon filter is not wet. C. Check that the vent hole in the pump housing is not blocked.
5	The service station drains slowly.	A. Discharge pipe is too long or has an excessive number of bends. B. The pump housing is leaky. C. Hydraulics or grinder blocked.	A. Increase discharge pipe size. Change pipework to reduce number of bends. Change bends to soft bends. B. Replace the pump housing (servicepart). C. Check and clean the hydraulics and grinder.
6	Rattling noise from the lifting station, but water is evacuated.	A. Foreign body hitting the impeller/grinder.	A. Remove the foreign body.
7	Odour from the tank.	A. Carbon filter contaminated.	A. Replace the carbon filter.

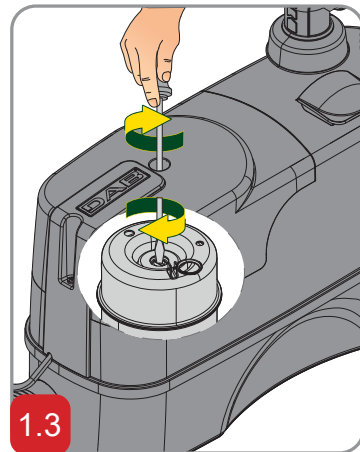
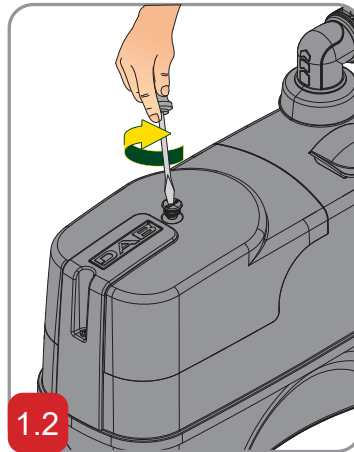
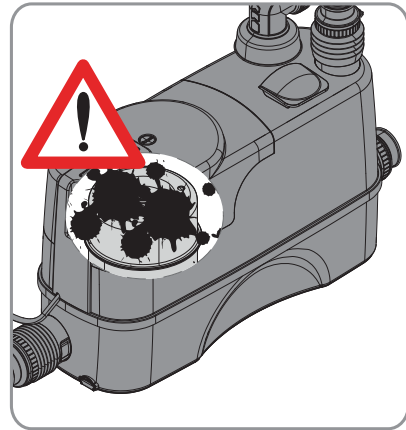
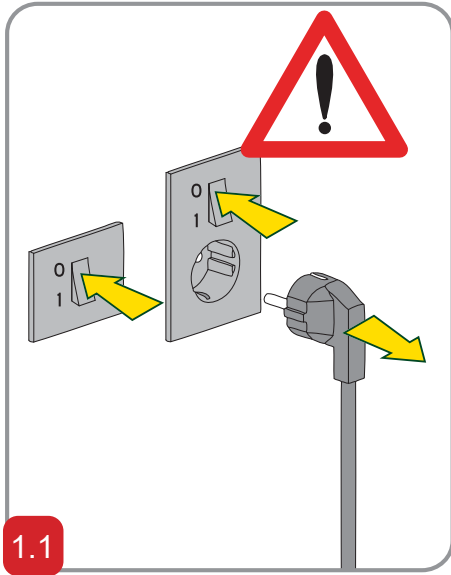



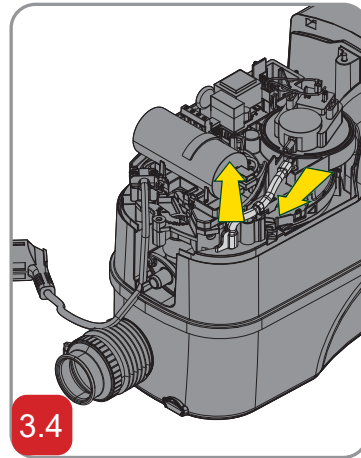
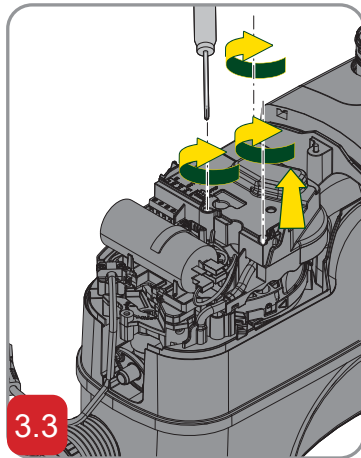
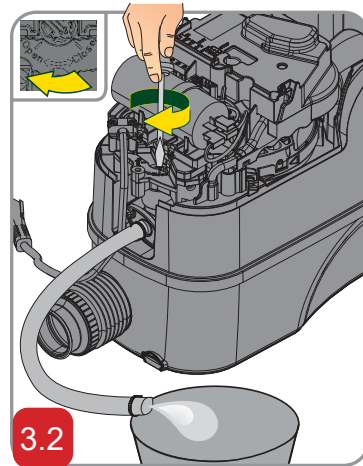
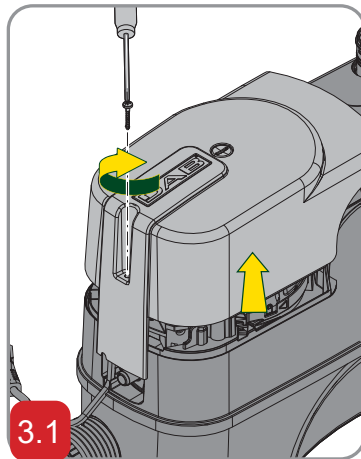
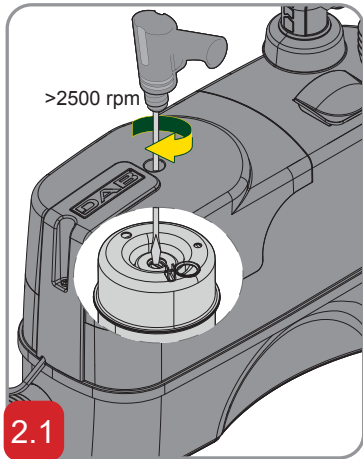

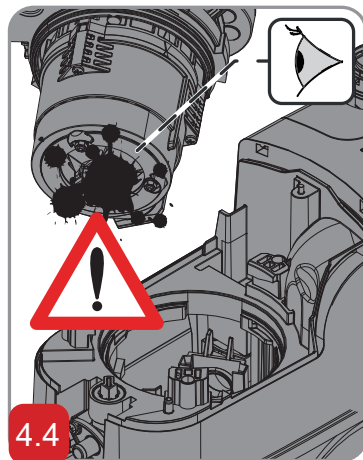
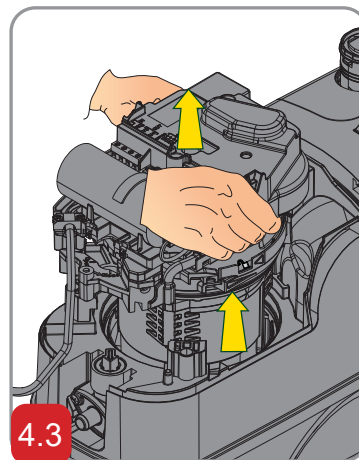
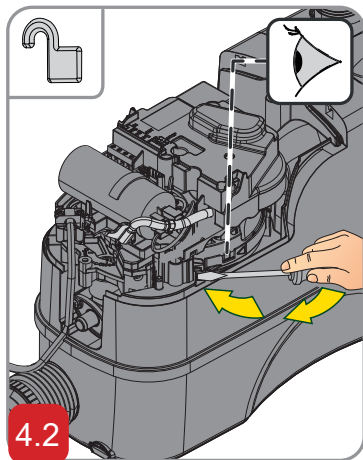
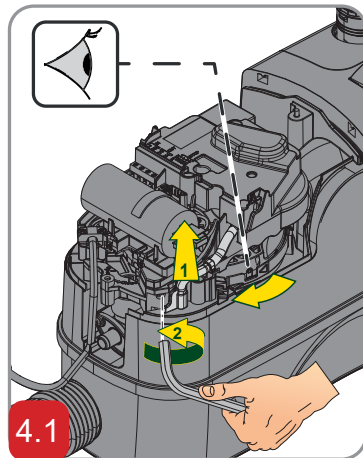
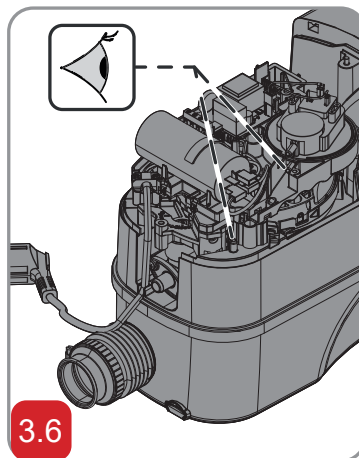
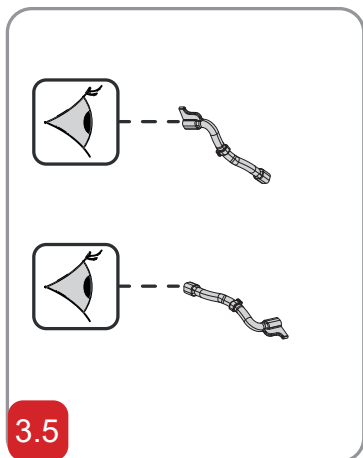

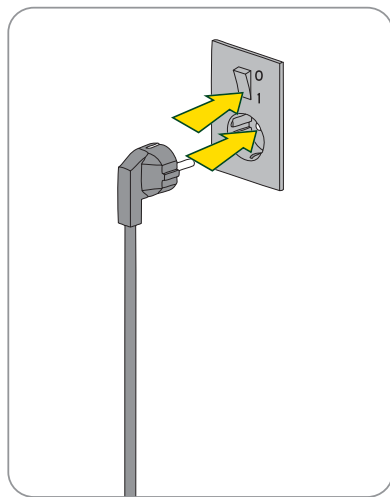
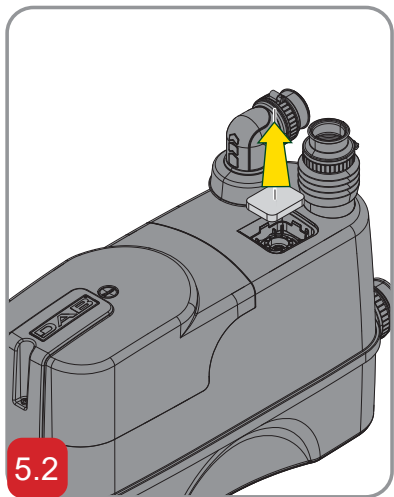
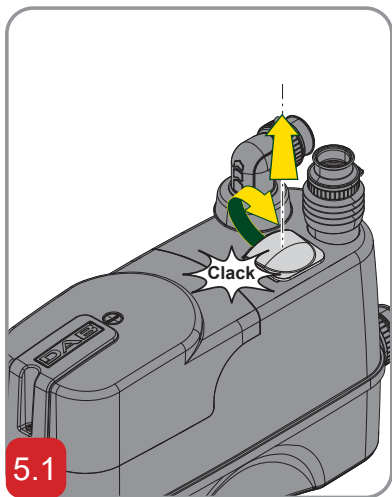

**DAB PUMPS LTD.**

6 Gilbert Court  
Newcomen Way  
Severalls Business Park  
Colchester  
Essex  
C04 9WN - UK  
salesuk@dwtgroup.com  
Tel. +44 0333 777 5010

**DAB PUMPS B.V.**

Albert Einsteinweg, 4  
5151 DL Drunen - Nederland  
info.netherlands@dwtgroup.com  
Tel. +31 416 387280  
Fax +31 416 387299

**OOO DAB PUMPS**

Novgorodskaya str. 1, block G  
office 308, 127247, Moscow - Russia  
info.russia@dwtgroup.com  
Tel. +7 495 122 0035  
Fax +7 495 122 0036

**DAB PUMPS HUNGARY KFT.**

H-8800  
Nagykanizsa, Buda Ernő u.5  
Hungary  
Tel. +36 93501700

**DAB PUMPS OCEANIA PTY LTD**

426 South Gippsland Hwy,  
Dandenong South VIC 3175 – Australia  
info.oceania@dwtgroup.com  
Tel. +61 1300 373 677

**DAB PUMPS IBERICA S.L.**

Calle Verano 18-20-22  
28850 - Torrejón de Ardoz - Madrid Spain  
Info.spain@dwtgroup.com  
Tel. +34 91 6569545  
Fax: + 34 91 6569676

**DAB PUMPS INC.**

3226 Benchmark Drive  
Ladson, SC 29456 - USA  
info.usa@dwtgroup.com  
Tel. 1- 843-797-5002  
Fax 1-843-797-3366

**DAB PUMPEN DEUTSCHLAND GmbH**

Tackweg 11  
D - 47918 Tönisvorst - Germany  
info.germany@dwtgroup.com  
Tel. +49 2151 82136-0  
Fax +49 2151 82136-36

**DAB PUMPS DE MÉXICO, S.A. DE C.V.**

Av Amsterdam 101 Local 4  
Col. Hipódromo Condesa,  
Del. Cuauhtémoc CP 06170  
Ciudad de México  
Tel. +52 55 6719 0493

**DAB PUMPS S.p.A.**

Via M. Polo, 14 - 35035 Mestrino (PD) - Italy  
Tel. +39 049 5125000 - Fax +39 049 5125950  
www.dabpumps.com

**DAB PUMPS B.V.**

'tHofveld 6 C1  
1702 Groot Bijgaarden - Belgium  
info.belgium@dwtgroup.com  
Tel. +32 2 4668353

**DAB PUMPS SOUTH AFRICA**

Twenty One industrial Estate,  
16 Purlin Street, Unit B, Warehouse 4  
Olifantsfontein - 1666 - South Africa  
info.sa@dwtgroup.com  
Tel. +27 12 361 3997

**DAB PUMPS POLAND SP. z.o.o.**

Ul. Janka Muzykanta 60  
02-188 Warszawa - Poland  
polska@dabpumps.com.pl

**DAB PUMPS (QINGDAO) CO. LTD.**

No.40 Kaituo Road, Qingdao Economic &  
Technological Development Zone  
Qingdao City, Shandong Province - China  
PC: 266500  
sales.cn@dwtgroup.com  
Tel. +86 400 186 8280  
Fax +86 53286812210