

BIANCO rainsaver™



Bianco RainsaverMK5 Installation and Operating Instructions

Bianco RainsaverMK5 uses WaterMarked components and incorporates a dual check valve for back flow prevention for the mains water.



Bianco Rainsaver MK5 Installation and Operating Instructions

1. Introduction:

The **Bianco Rainsaver MK5** is an Automatic Rainwater / Mains Water Changeover Device designed to provide automatic mains back up for Pressure Pump supply systems.

The **Bianco Rainsaver MK5** is designed to be installed in conjunction with a DAB, BIANCO or UNIVERSAL surface mounted or submersible Pressure Pump supply system that is fitted with an independent **PRESSURE AND FLOW CONTROLLER** with **LOSS OF PRIME PROTECTION** and **AUTOMATIC RE-START** that is set at **2.2 bar start pressure**.

WARNING! The Bianco Rainsaver MK5 is NOT A PUMP CONTROLLER!

2. General Specifications:

Maximum water temperature (mains + pump): 40° C.

Maximum recommended continuous pump flow: 120 litres per minute.

Maximum recommended pump pressure: 1000 kPa.

Maximum recommended mains inlet pressure: 1000 kPa.

3. Operation:

The **Bianco Rainsaver MK5** supplies clean rainwater from a rainwater tank and associated pressure pump system, to toilets, laundry, garden taps and household.

Mains water is also connected to the **Bianco Rainsaver MK5** as an automatic back up.

When the pressure pump ceases to supply water because it has detected that the rain water level in the tank is too low, or if there is a power or pump failure, the **Bianco Rainsaver MK5** will automatically change over to supply mains water to meet the household needs.

When the rainwater supply is replenished and auto restart has commenced, or the power is restored to the pump, the pump will pressurise the **Bianco Rainsaver MK5** and the unit will switch back automatically to supplying tank water to the household.

4. Installation:

4.1 Rainsaver MK5 installation.

The **Bianco Rainsaver MK5** can be **Wall mounted** or **Pump Mounted** i.e. mounted directly onto a pressure pump outlet.

4.1.1 Wall Mounting:

The **Rainsaver MK5** can be remotely mounted any distance from the pump.

The **Rainsaver MK5** can be mounted outdoors.

The **Rainsaver MK5** can be mounted with the mains inlet pointing in either direction when supported by the pipework.

4.12 Pump Mounting:

Rainsaver MK5 can be mounted directly onto the outlet of the pump controller.

4.2 Filtration and Water Quality

The **Bianco Rainsaver MK5** is designed to operate on **clean** rainwater and clean mains water supply, and as such, the rainwater tank should be fitted with an inlet strainer, preferably shaded type to reduce algae, and a suitable first flush device.

White International strongly recommends the use of a strainer or filter upstream with easy access for period cleaning from both the rainwater and mains inlet connections of the **Bianco Rainsaver MK5**.

Additional water filters may be required. Also check the water tank and first flush diverter as per manufacturers' instructions regarding periodic servicing that is required.

Filters need to be checked regularly as reduced flow caused by blocked filters can damage pumping equipment.

4.3 Plumbing

Plumbing connections should be carried out by a licensed plumber.

Use of flexible pipe connections and isolation vales is recommended to assist in alignment and servicing and to reduce any transmitted noise.

All pipe-work and outlet fittings from the Bianco Rainsaver MK5 must be labelled to AS3500.

The **Bianco Rainsaver MK5** control incorporates a dual check valve to prevent cross connection between mains and rainwater. Connection to an underground rain water tank, or local water supply authorities, may require additional, or higher safety level, back flow prevention, and your licensed plumber can advise you on this.

The incorporation of an additional "Tee" fitting between the tank water pressure pump supply, and the **Bianco Rainsaver MK5** lower "PUMP INLET", will allow the householder to use collected rainwater, but NOT mains water supply, to irrigate gardens and lawns, or wash cars.

Cautions:

In conjunction with this manual, read and understand the installation and maintenance manual for the water pump that is to be connected to the **Bianco Rainsaver MK5**.

The **Bianco Rainsaver MK5** and any pump connected to it are not to be used by children or infirm persons and must not be used as a toy.

A licensed plumber should carry out plumbing connections.

Servicing of the **Bianco Rainsaver MK5** and, or water pump should only by carried out by qualified persons.

Do not clean the **Bianco Rainsaver MK5** with abrasive or petroleum based fluids, and do not use hydrocarbon propelled sprays on or around the **Bianco Rainsaver MK5**.

5. Sound Emissions.

The **Bianco Rainsaver MK5** is virtually silent but may emit noises associated with the flow of water through the unit.

In any case, the pump, which is connected to the **Bianco Rainsaver MK5**, may emit sound levels, which may inconvenience you or your neighbours, or may operate during normal sleeping hours, which may be prohibited by local government regulations. If this is the case, your pump can be switched off during the night or may be operated from a time clock. Your **Bianco Rainsaver MK5** will automatically supply your house with Mains water supply while the pump is inactive.

6. Maintenance.

Ensure that water flowing through the **Rainsaver MK5** is as free from dirt and foreign matter as conditions allow.

Ease of accessibility will aid any maintenance and reduce any servicing costs if required.

Periodically inspect the rainwater tank inlet strainer and the first flush device. Periodically inspect filters downstream and strainers if fitted upstream from the **Bianco Rainsaver MK5** every 6 months depending on water quality and usage.

Operate the Rainsaver on mains regularly or at least once a month by turning the power off to the pump

7. Trouble shooting.

Consult the manuals supplied with the water pump and its controller if fitted in addition to the following guide.

1. Mains flow is not available or low when Pump is switched off or not operating.
 - a. Isolation valve, if fitted, is not open.
 - b. Debris has blocked the inlet.
 - c. External Inlet strainer / filter, if fitted, are blocked.
2. Pump flow is not available or low when pump is operating through Bianco Rainsaver MK5.
 - a. Pump has lost its prime.
 - b. Isolation valve, if fitted, is not open.
 - c. External Inlet strainer / filter, if fitted, is blocked.
3. Pump does not start.
 - a. Rainwater tank is empty.
 - b. Power supply is off.
 - c. Pump controller is not installed correctly or jammed with debris.
 - d. Pump has a fault.
4. Pump does not stop.
 - a. Leak in plumbing.
 - b. Pump controller is not installed correctly or jammed with debris

For after sales service please contact White International Customer Service: 1300 783 601.

8. Pumps

Pumps and pump controllers must be accessible and fitted with barrel unions for service and maintenance.

All surface mounted pumps must be protected from the elements with a suitable pump cover.

Submersible pump accessories such as pump stands, high inlets, floating suction hose kits assist in the pumping cleaner water that is found at higher levels in the rainwater tank.

9. Water Tanks

Water borne algae and roof litter can accumulate at the bottom of your rainwater tank that can be sucked up by your pump. To reduce filter blockages we recommend that suction outlets on rainwater tanks be 100 mm from the bottom of the tank, and submersible pumps elevated by 90 mm .

10. Installation Dimensions

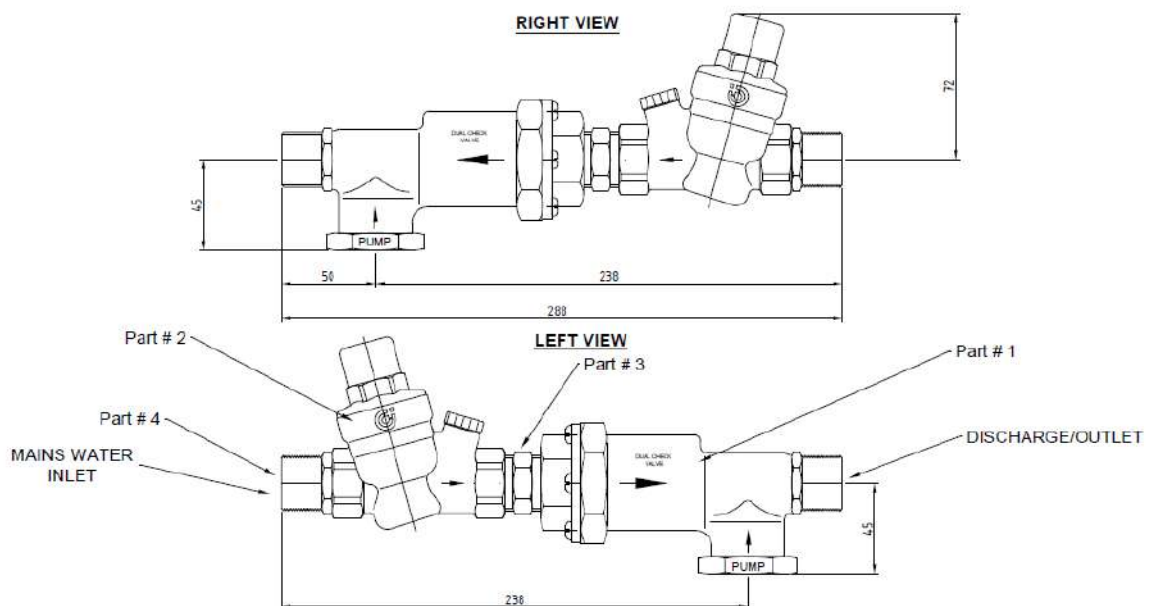

Typical Installations.

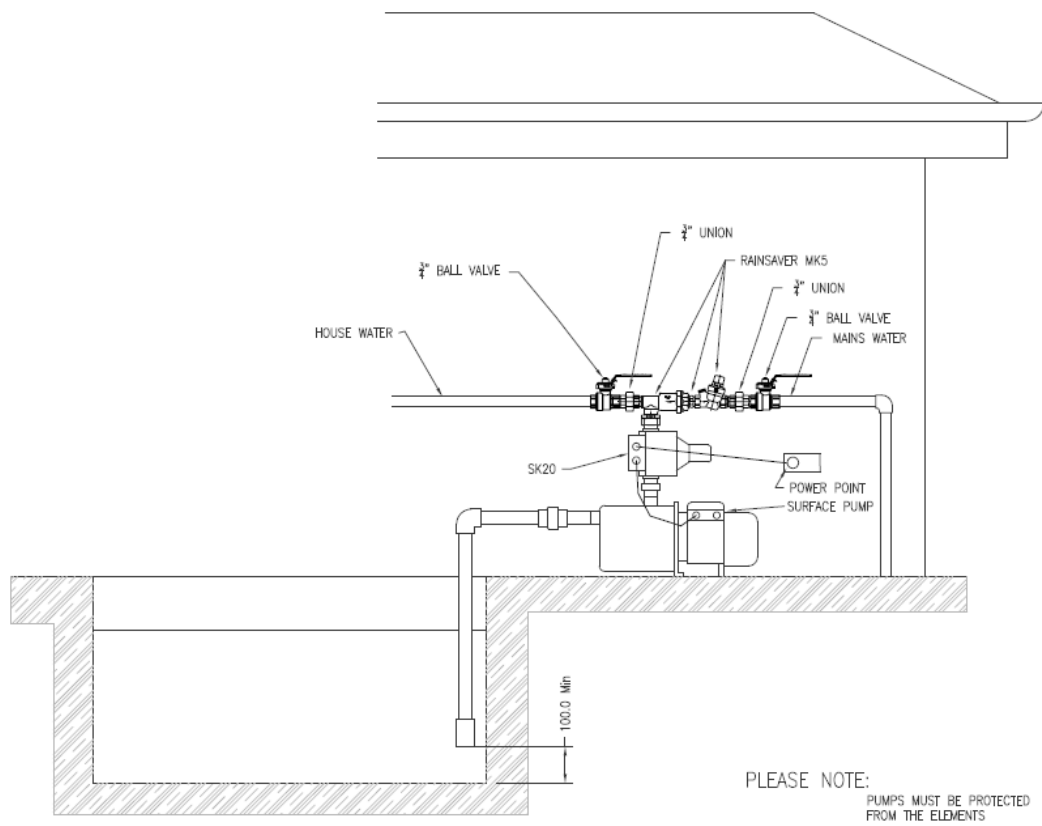
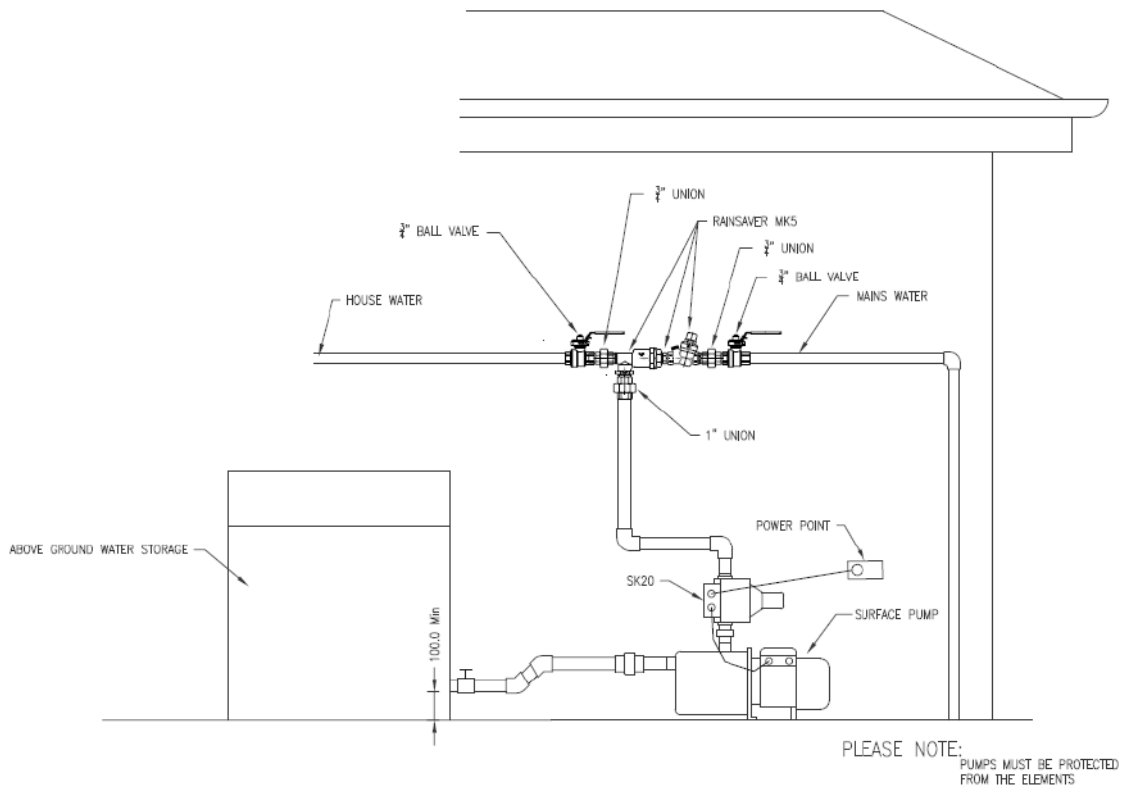

DAB, BIANCO or UNIVERSAL surface mounted pumps fitted with SK20 pump controller.
RAINSAVERMK5 can be pump or pipe mounted.

Typical Installations.

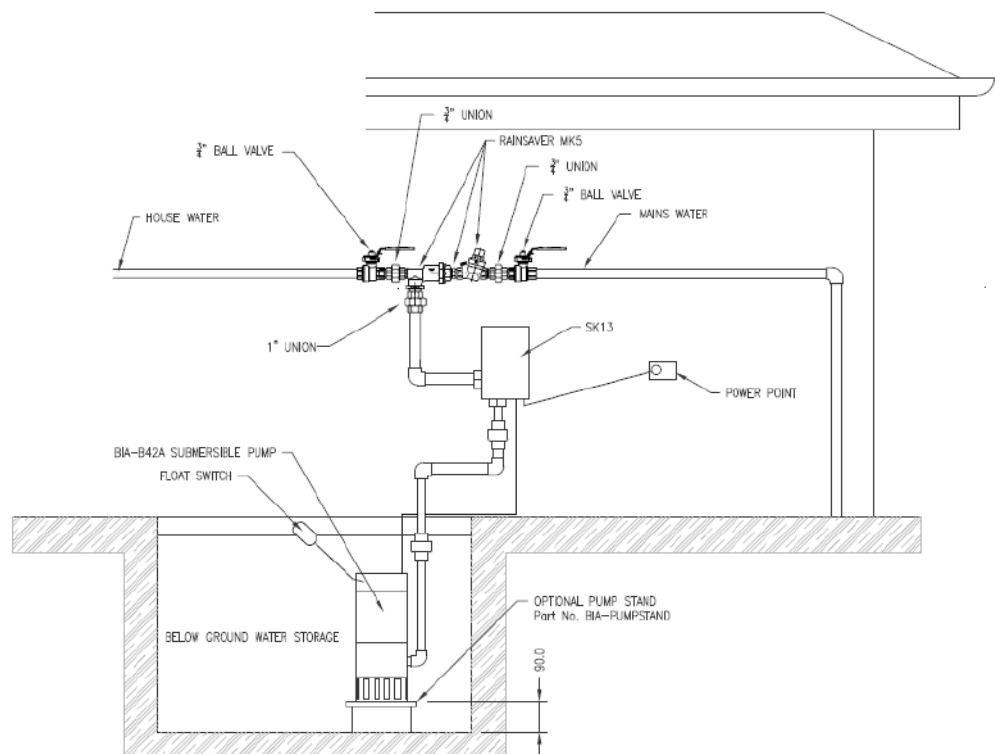
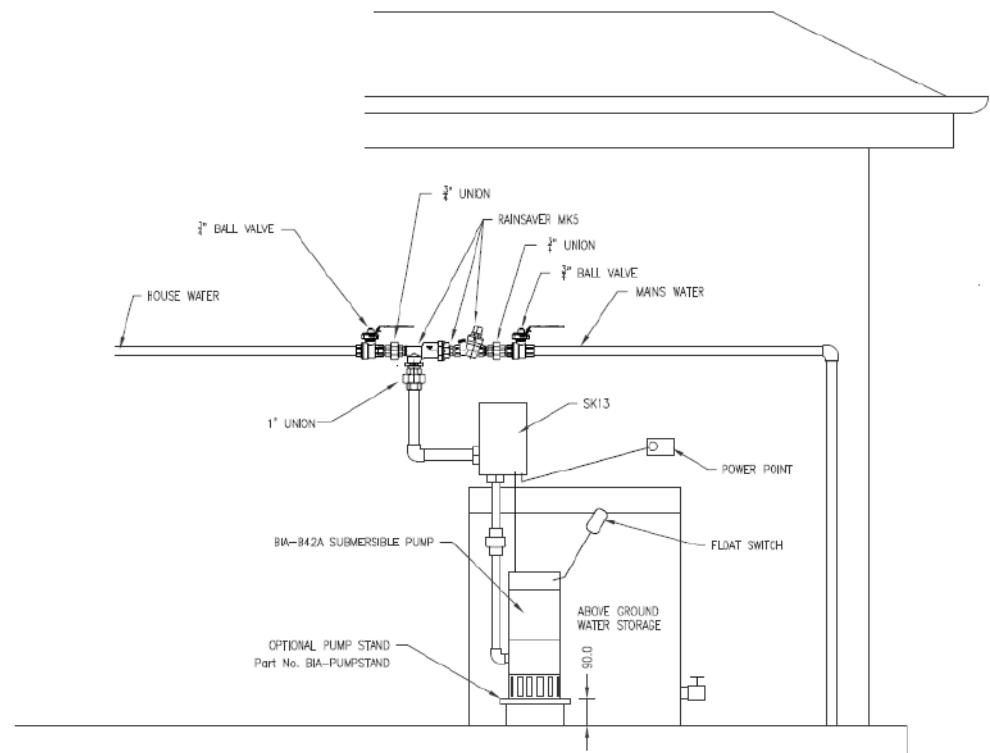

BIANCO B42A or JH8003P submersible pumps with remote SK13 pump controller.
 RAINSAVERMK5 can be pipe mounted.

Typical Installations.

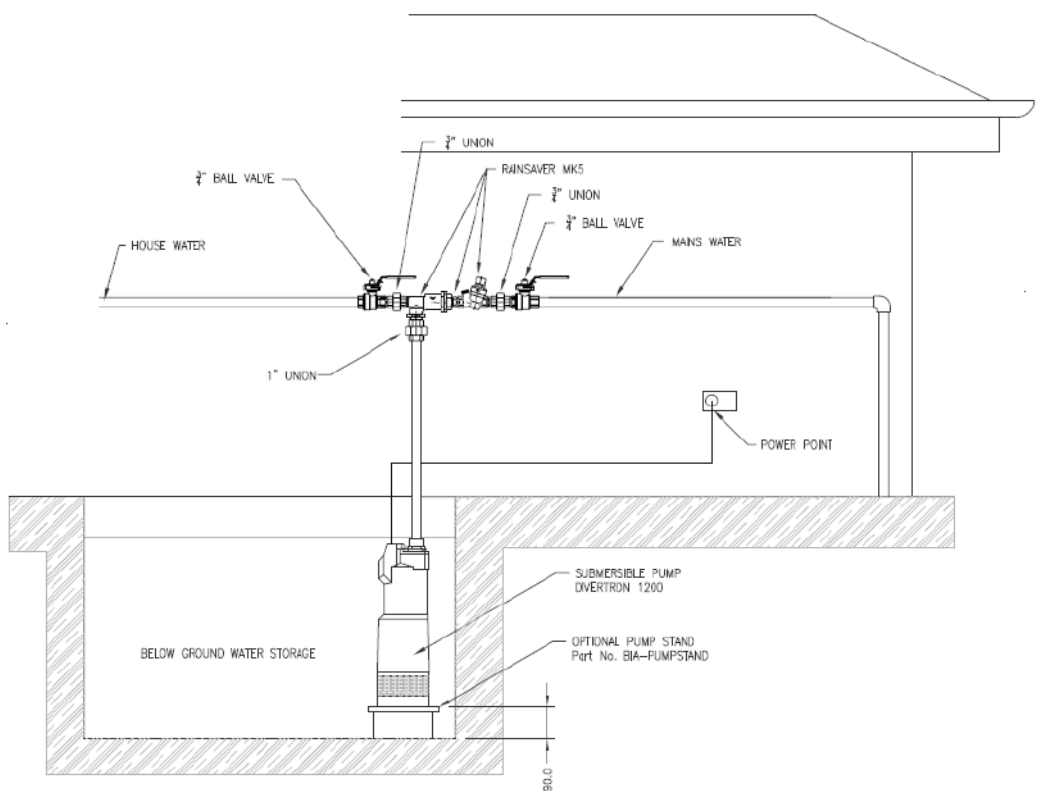
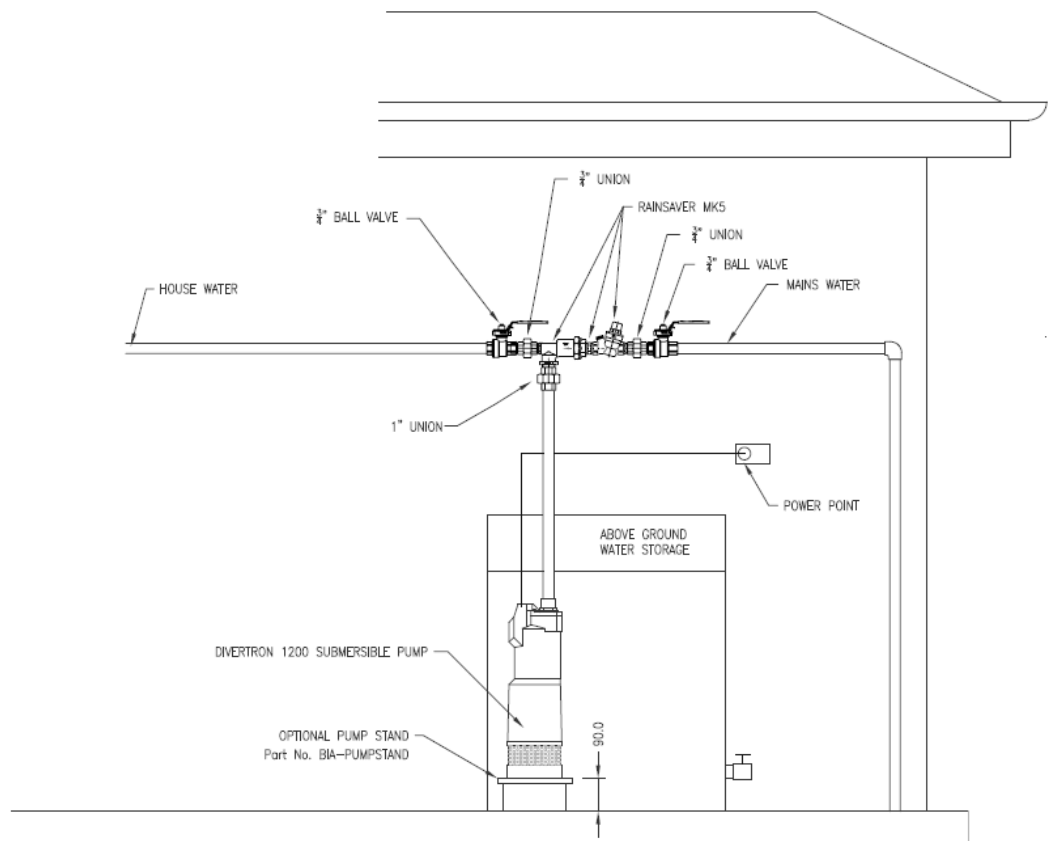

DAB DIVERTRON 1200 submersible pump with internal pump controller.
 RAINSAVERMK5 can be pipe mounted.

Accessories.

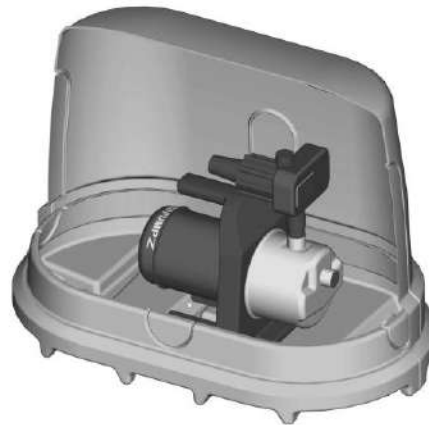

Pump Cover protects pump from the elements.



Pump stand for submersible pumps.
Pumps pump cleaner water.



Piggy back float switch option for Divertron



DAB Divertron X conversion kit allows pumping from higher level and connection to floating suction kits to pump cleaner water higher in the tank.



MK5 2 YEAR REPLACEMENT WARRANTY

Terms & Conditions

- 1) White International Pty Ltd / White International NZ Ltd (White International) warrant that all products distributed are free from defects in workmanship and materials, for their provided warranty period as indicated on the top or opposite side of this document. Subject to the conditions of the warranty, White International will repair any defective products free of charge at the premises of our authorised service agents throughout Australia and New Zealand if a defect in the product appears during the warranty period. If you believe that you have purchased a defective product and wish to make a claim under this warranty, contact us on our Sales Hotline on 1300 783 601, or send your claim to our postal address or fax line below and we will advise you as to how next to proceed. You will be required to supply a copy of your proof of purchase to make a claim under this warranty.
- 2) This warranty excludes transportation costs to and from White International or its appointed service agents and excludes defects due to non-compliance with installation instructions, neglect or misuse, inadequate protection against the elements, low voltage or use or operation for purposes other than those for which they were designed. For further information regarding the suitability of your intended application contact us on our Sales Hotline on 1300 783 601. If you make an invalid claim under this warranty, the original product will be sent back to you unrepai red.
- 3) This warranty refers only to products sold after the 1st January 2012, and is not transferable to another product type and only applies to the original owner, purchaser or end user, and is in addition to the consumer guarantees found within the Competition and Consumer Act 2010 (Cth) for goods purchased in Australia and the Consumer Guarantees Act 1993 (NZ) for goods purchased in New Zealand.
- 4) Our goods come with guarantees that cannot be excluded under the Australian Consumer Law. You are entitled to a replacement or refund for a major failure and for compensation for any other reasonably foreseeable loss or damage. You are also entitled to have the goods repaired or replaced if the goods fail to be of acceptable quality and the failure does not amount to a major failure.
- 5) To the fullest extent permitted by law, White International excludes its liability for all other conditions or warranties which would or might otherwise be implied at law. To the fullest extent permitted by law, White International's liability under this warranty and any other conditions, guarantees or warranties at law that cannot be excluded, including those in the Competition and Consumer Act 2010 (Cth), is expressly limited to:
 - (a) in the case of products, the replacement of the product or the supply of equivalent product, the payment of the cost of replacing the product or of acquiring an equivalent product or the repair of the product or payment of the cost of having the product repaired, is at the discretion of White International or a 3rd party tribunal elected under the Competition and Consumer Act 2010 (Cth) for goods purchased in Australia and the Consumer Guarantees Act 1993 (NZ) for goods purchased in New Zealand; and
- 6) To the fullest extent permitted by law, this warranty supersedes all other warranties attached to the product or its packaging.
- 7) In the case of services, supplying the services again or the payment of the cost of having the services supplied again, is at the discretion of White International or a 3rd party tribunal elected under the Competition and Consumer Act 2010 (Cth) for goods purchased in Australia and the Consumer Guarantees Act 1993 (NZ) for goods purchased in New Zealand.
- 8) Our warranty commences from the date of purchase of the above mentioned pumps. Proof of purchase is required before consideration under warranty is given. Record your date of purchase in the space below and retain this copy for your records.

Date of Purchase Model Purchased



WHITE INTERNATIONAL PTY LTD
ABN 48 000119380
52-60 Ashford Ave, MILPERRA NSW 2214
PO BOX 304, MILPERRA LPO NSW 2214
Ph: 02 9783 6000 Fax: 02 9783 6001
Customer Service Hotline: 1300 783 601
Customer Service Faxline: 02 9783 6003
EMAIL: Sales Enquiries: info@whiteint.com.au

WHITE INTERNATIONAL NZ LTD
15G Kerwyn Ave, East Tamaki, AUCKLAND, NZ
PO BOX 12-704, PENROSE, AUCKLAND
Ph: 09 579 9777 Fax: 09 579 7775
Customer Service Hotline: 0800 509 506
Customer Service Faxline: 0800 804 344
EMAIL: General Info Enquiries: sales@whiteint.co.nz