



## High Head Progressive Displacement Grinder Pump

BIA-PDG150MA	800252
BIA-PDG150M	800587
BIA-PDG150T	800589



PDG150-CF32 801985

## 1. Contents

1. Contents .....	2
2. Conformity .....	2
3. Introduction .....	3
4. Pump Performance, Dimensions and Common Spares.....	3
4. Technical Specifications.....	4
6. ISO 7010 Symbols used in this manual.....	4
7. Warnings and Cautions .....	5
8. Electrical Connections.....	6
9. Intended application .....	6
10. Installation .....	6
11. Commissioning.....	7
12. Maintenance .....	8
12. Cutaway view and Parts list.....	9
13. Faults and Trouble Shooting Guide.....	10
14. Warranties – Terms and Conditions .....	11

## 2. Conformity



IEC 60335.2.41

### 3. Introduction

Congratulations on the purchase of your Bianco Progressive Displacement Grinder Pump.

The Bianco PDG is a legacy pump model, proven in service over the last decade. Suitable for pumping biological wastewater / sewage in applications requiring high head pressures

The PDG150 with its robust cast iron construction and proven high carbon martensitic stainless steel macerating ring grind solids and fibrous matter into small particles that can be safely pumped through small diameter piping.

Available options:

- 240V Single Phase pump, with integrated control float PN 800252
- 240V Single Phase pump without a control float fitted PN 800587
- 415V Three Phase model without a control float fitted PN 800589

The pump can be installed free standing or on a rugged cast iron coupling foot.

### 4. Pump Performance, Dimensions and Common Spares

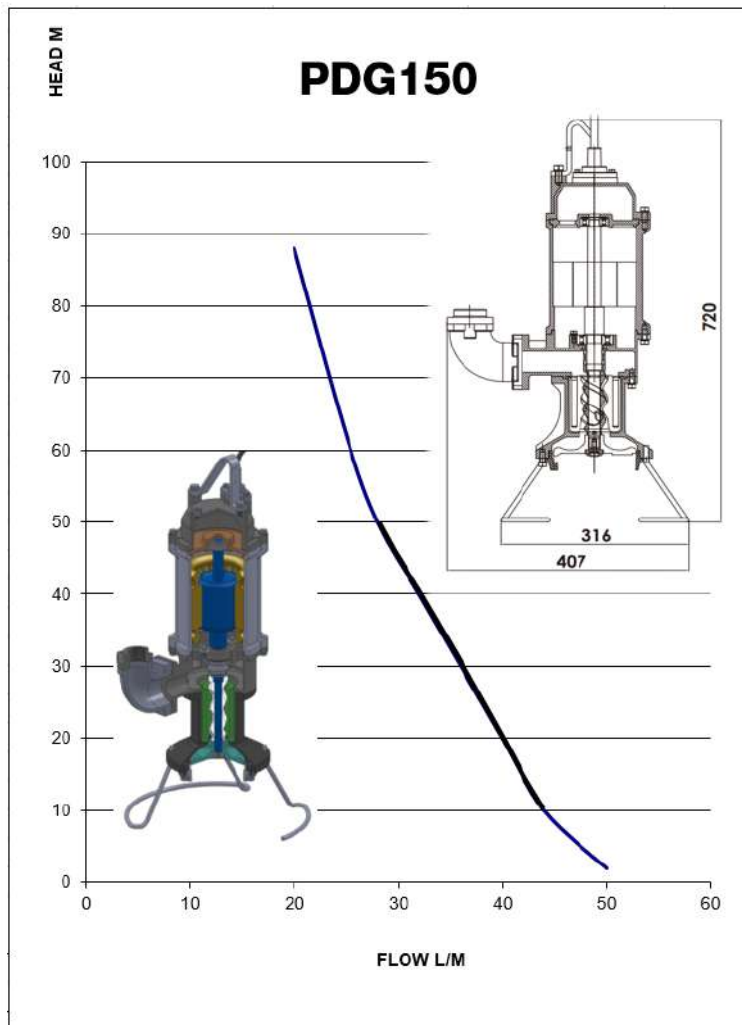

BIA-PDG150MA 800252 1Ph with float  
 BIA-PDG150M 800587 1Ph no float  
 BIA-PDG150T 800589 3Ph no float

#### Common Spares and Accessories

801978	(14) Screw Rotor
801979	(15) Stator Rubber
801980	(15a) Stator cover
801981	(20) Mechanical seal
801982	(16) Cutter
801983	(17) Cutter Ring

801985	Coupling Foot
--------	---------------

805649	Start Capacitor 300UF
--------	-----------------------







805650	Run Capacitor 30UF
--------	--------------------

## 4. Technical Specifications

<b>Function</b>	High Head Pump with Grinding Mechanism
<b>Control</b>	Automatic float or preferably by external controller
<b>In-built protection</b>	Auto re-setting thermal overload
<b>Power Supply Voltage</b>	230V +/- 15%% 1 ph 50/60Hz AC: 150M and MA models 415V +/- 15%% 3 ph 50/60Hz AC: 150T models
<b>Motor rpm</b>	50Hz 1450 rpm / 60Hz 1750 rpm
<b>Maximum Submersion depth</b>	8 meters
<b>IP Rating</b>	IP68
<b>Liquid temp range</b>	0 - 40°C. Never to exceed 50 deg C
<b>IP Rating</b>	IP68
<b>Dimensions and Outlet</b>	407L x 316W x 720H. Outlet 32mm / 1 ¼"
<b>Weight</b>	40kg

Model No.	Motor No Load Current (A)	Motor No Load Wattage (W)	Maximum Current (A)	Full Load Current (A)
PDG150M and MA	4.5A	640W	7A	6.3A
PDG150T	1.3A	430W	3A	2.1A

## 6. ISO 7010 Symbols used in this manual

	Warning - Electrical safety
	Warning – Potential consequences of use outside of intended application(s). Includes environmental condition warnings.
	Mandatory warning
	Warning to disconnect power
	Read carefully
	Potential health hazard if instructions not followed

## 7. Warnings and Cautions

	Read the manual carefully before starting and retain for future reference.
	Prior to starting installation or maintenance the pump must be disconnected from the power supply. Allow 20 minutes for the motor to cool to prevent the risk of personal injury
	Any changes or modification to the wiring must be carried out by competent, skilled and suitably qualified personnel only.
	A qualified electrician should correctly size and install circuit breakers to protect the power supply. The fitment of additional surge protection is recommended.
	White International Strongly recommend the use of additional pump protection – specifically fast acting underload, over-load and ‘pump stall’ (locked rotor) protections
	The PDG150 is an intermittent duty pump designed for pumping sanitary sewage. It is not a dewatering or trash pump
	This appliance is not intended for use by persons (including children) with reduced physical, sensory or mental capabilities, or lack of experience and knowledge, unless they have been given supervision or instruction concerning use of the appliance by a person responsible for their safety. Children should be supervised to ensure that they do not play with the appliance.
	Sewage water gives off methane and hydrogen sulphide gases, both of which can be highly poisonous. Never enter a pump chamber until it has been properly vented and tested and adhere to Health and Safety regulations with respect to confined spaces
	The pump must be cleaned and disinfected, inside the pumping chamber and all exterior surfaces, prior to servicing and examination of the volute plate
	Always ensure a suitable lifting cord is used Pump weight is 40kg, use suitable lifting equipment

## 8. Electrical Connections

It is good practice to locate the controller as close to your water source as possible and near to a suitable power supply.

Always use an electrical outlet that is protected by Residual Current Device (RCD) Safety Switch with a trip current of 30mA or less. A Safety switch is required by Australian/New Zealand Standard AU/NZS 60335.1-2011.

This must be connected by a suitably qualified technician.



The inbuilt auto-resetting thermal overloads are not intended as the primary means of pump protection.

White International strongly recommend the use of external pump control and protection modules, such as the iCon iProtect, SPC or DPC. These provide instantaneous protection in locked rotor situations.

## 9. Intended application

The PDG150 is an intermittent duty pump designed for pumping sanitary sewage. It is not a dewatering or trash pump.

The pump is not intended for handling (severe) abrasive solutions, fuels or other flammable liquids, thinner, acids or other strong chemical solutions.



This pump is not to be installed in locations classified as **Hazardous** (Zone 1 or Zone 2)

The pump is a semi-positive displacement, progressing cavity pump. Its mechanism consists of a pump assembly with an integral sewage grinder and the shredder device (cutter ring). When running, the grinder mechanism pulverizes any solids and the slurry is able to be pumped by the pump rotor and stator through relatively small diameter piping.

Overheating due to dry running will damage the screw rotor or may cause it to weld to the pump body. **Dry running voids all applicable warranty.**



## 10. Installation

Sewage pumps must be installed in a tank that is vented in accordance with local regulations and that meets all applicable legislation.

The pump discharge pipe should be fitted with non-return valve close to the pump outlet.

After lowering a pump with a check valve or non-return valve into the liquid allow time for the pump case to fill to prevent air locks.



To help prevent air locking, in cases where the pump has no air vent located behind the discharge, it is recommended to create an extra air vent hole approx. 5mm dia. in the discharge pipe below the check valve. This air bleed hole must be cleaned before each reinstall.

Once the pump is installed, run the unit submerged to ensure the pump case is filled.

**Never** lift using the power cord.  
A lifting rope or chain is recommended.  
Unit weight 40kg

Mechanically secure the support legs  
**OR** bend outward slightly to ensure  
they remain in place.

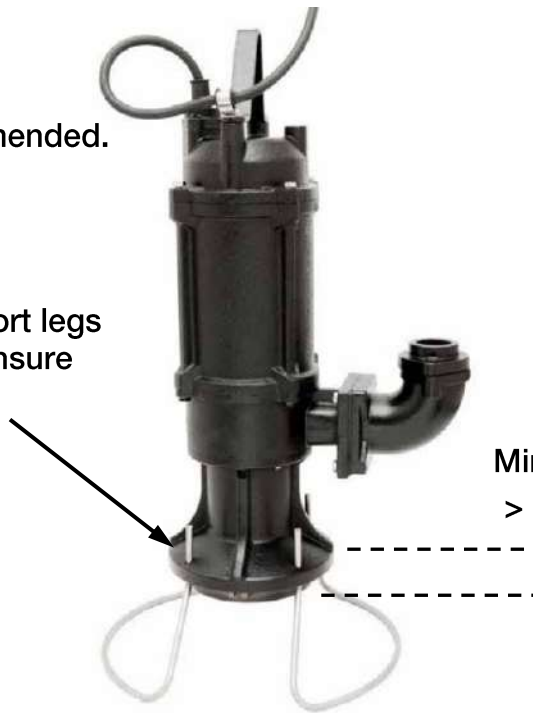

Minimum liquid level:  
> 50mm above inlet

*Typically, pressure sewer installations include a 'boundary kit' with dual check valves*

## 11. Commissioning



Warning: Severe injury may result from accidental contact with moving cutters. Stay well clear of the cutter mechanism any time power is connected to the pump.



Three phase pumps should be checked to ensure the direction of rotation is correct.  
Single Phase pumps do not require a rotation check

See **Section 10 – Installation.** for notes about avoiding air locking.



### Method

1. Run water into sump until the pump motor is covered.
2. Open gate valve in discharge line.
3. Turn the pump on.  
If pump runs and sump liquid does not pump down, stop the pump and close discharge gate valve.  
Then lift pump until sealing flange is open to vent off trapped air.  
Lower pump, open discharge valve, and start the pump again
4. Level control should be set so that pump turns off when level is about 50mm above inlet of pump suction and turns on when level is about 50mm or greater above motor.

**Caution: Never work on pump with power on. Make sure that the ground wire is securely connected and that the unit is properly grounded in accordance with local electrical regulations**





## 12. Maintenance

Grinder installations should be checked yearly for debris and/or build up which may interfere with the ON or OFF positions of all control floats.

Repair and service, other than cutter assembly maintenance, should be performed by experienced authorized personnel only,

### DISASSEMBLY OF SHREDDING RING AND GRINDER IMPELLER

1. Remove the 4 bolts from cutter ring seat and remove the ring seat.
2. Remove the nut from the shaft end. Hold the cutter by using pliers but take care as the cutter will slide down the shaft as you loosen the nut.
3. Clean the slots in the cutter seat.
4. **Never remove the elastomer stator** when you open to inspect.
5. Take care of the 4 cutter vanes as well as the inside of the cutter ring as it may have sharp edges. 
6. Clean the cutter ring with a wire brush and file smooth any nicked slots  
Replace any parts which are broken, appear bent or are worn
7. Before replacing grinder cutter, make sure the pump shaft cap screw is tight.
8. Ensure the cutter and the shaft turns freely by hand after reassembly.  
There should be no binding or tight spots after refastening. 

**Should there be any rub or drag on the shredding ring, loosen the 4 bolts on the cutter ring seat and tap lightly with a hammer to centre.**

To avoid misalignment and the risk of jamming the shredding ring and rotor, tighten the bolts evenly and in sequence to equal torque.



## 12. Cutaway view and Parts list

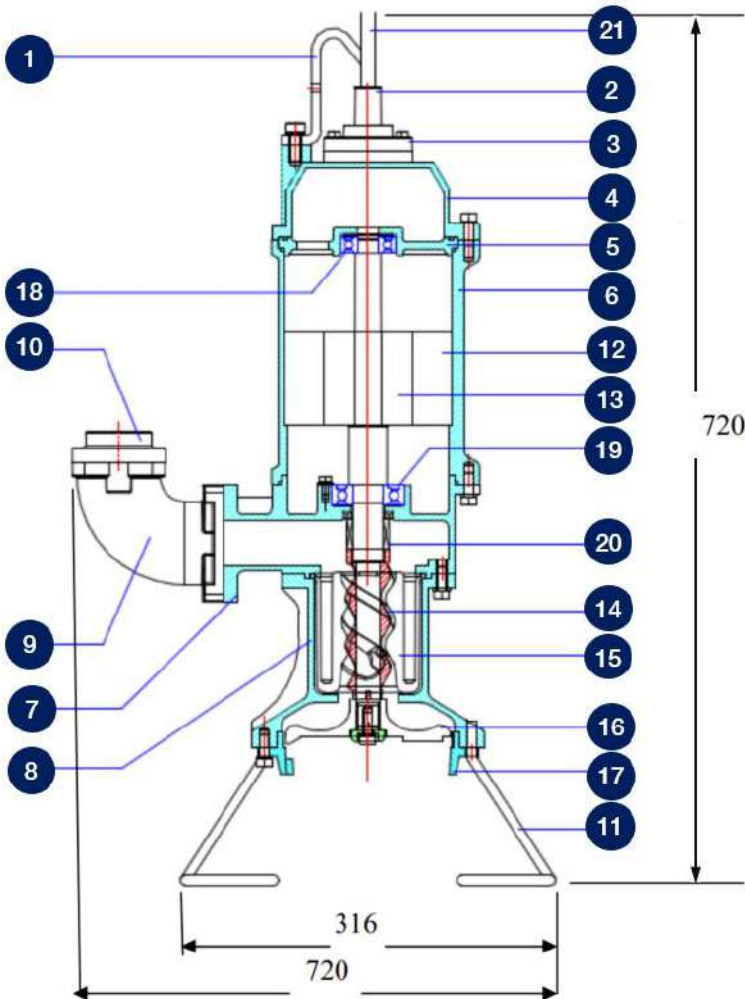

No	Description	Material
1	Handle	Steel Plated
2	Cable Gland	NBR
3	cable Cover	FC200
4	Top Cover	FC200
5	Bearing Cover	FC200
6	Motor housing	FC200
7	Pump Casing	FC200
8	Cutter Seat	FC200
9	Elbow	FC200
10	Flange	FC200
11	Base	SUS304
12	Stator	Laminated Steel
13	Rotor	SUS410
14	Screw Rotor	SUS304
15	Elastomer Stator	Proprietary Compound
16	Cutter	SUS440
17	Cutter-Ring	SUS440
18	Bearing	SUJ2
19	Bearing	SUJ2
20	Mech. Seal	SIC/SIC

## 13. Faults and Trouble Shooting Guide

### No liquid delivered

- Pump airlocked
- Discharge head too high
- Pump or piping blocked

### Insufficient liquid delivered

- Discharge head too high
- Impeller (screw rotor/elastomer stator) or cutters partially blocked or damaged

### Insufficient discharge pressure

- Air or gases in liquid or piping line
- Screw Rotor damaged

### Pump overloads motor

- Unexpected change to the Specific gravity or viscosity of the liquid
- Worn bearings

### Head lower than rating

- Pumping too much liquid
- Pump clogged
- Worn bearings
- Worn screw rotor or elastomer stator

### Pump is noisy

- Worn bearings
- No diametric clearance between radial cutter and cutter ring - check the gap.

Symptom	Possible Cause
Pump will not start or run	Incorrect wiring in control panel. Blown panel or circuit breaker fuse. Thermal overload open, defective capacitor circuit, cutter or impeller assembly clogged. Float assembly faulty or stuck in the off position. Liquid in pump motor.
Pump will not shut off	Air locking. Float assembly faulty or stuck in the on position. Incoming sewage exceeds capacity of pump.
Pump operates but delivers little or no water	Intake clogged with grease or sludge. Pump air locked - clear the vent hole. Clogged discharge line. Operating near shut-off head.
Pump starts and stops too often.	Non-return valve stuck open or faulty. Sump pit too small to handle incoming sewage. Level control adjustment incorrect. Thermal overload tripping.
Motor overheats and trips on overload.	Incorrect voltage. Impeller assembly or cutter blocked. Negative head (discharge lower than intake of pump). Faulty 'off' float. Pump running continuously at low water level. Low oil level in motor casing.
Grease and solids accumulate in pit around the pump	Break up solids and run pump with water running into the pit. Allow level to lower to the pump intake. Continue until solids are cleared from the pit.  Do not drain kitchen grease down the sink

## 14. Warranties – Terms and Conditions

This warranty is given in addition to the consumer guarantees found within the Australian Competition and Consumer Act 2010 (Cth) for goods purchased in Australia and the Consumer Guarantees Act 1993 NZ for goods purchased in New Zealand:



1) White International Pty Ltd / White International NZ Ltd (White International) warrant that all products distributed are free from defects in workmanship and materials, for their provided warranty period as indicated on the top or opposite side of this document. Subject to the conditions of the warranty, White International will repair any defective products free of charge at the premises of our authorised service agents throughout Australia and New Zealand if a defect in the product appears during the warranty period. If you believe that you have purchased a defective product and wish to make a claim under this warranty, contact us on our Sales Hotline on 1300 783 601, or send your claim to our postal address or fax line below and we will advise you as to how next to proceed. You will be required to supply a copy of your proof of purchase to make a claim under this warranty.

2) This warranty excludes transportation costs to and from White International or its appointed service agents and excludes defects due to non-compliance with installation instructions, neglect or misuse, inadequate protection against the elements, low voltage or use or operation for purposes other than those for which they were designed. For further information regarding the suitability of your intended application contact us on our Sales Hotline on 1300 783 601. If you make an invalid claim under this warranty, the original product will be sent back to you unrepairs.

3) This warranty refers only to products sold after the 1st January 2012, and is not transferable to another product type and only applies to the original owner, purchaser or end user, and is in addition to the consumer guarantees found within the Competition and Consumer Act 2010 (Cth) for goods purchased in Australia and the Consumer Guarantees Act 1993 (NZ) for goods purchased in New Zealand.

4) Our goods come with guarantees that cannot be excluded under the Australian Consumer Law. You are entitled to a replacement or refund for a major failure and for compensation for any other reasonably foreseeable loss or damage. You are also entitled to have the goods repaired or replaced if the goods fail to be of acceptable quality and the failure does not amount to a major failure. **2 YEAR WARRANTY**

5) To the fullest extent permitted by law, White International excludes its liability for all other conditions or warranties which would or might otherwise be implied at law. To the fullest extent permitted by law, White International's liability under this warranty and any other conditions, guarantees or warranties at law that cannot be excluded, including those in the Competition and Consumer Act 2010 (Cth), is expressly limited to: (a) in the case of products, the replacement of the product or the supply of equivalent product, the payment of the cost of replacing the product or of acquiring an equivalent product or the repair of the product or payment of the cost of having the product repaired, is at the discretion of White International or a 3rd party tribunal elected under the Competition and Consumer Act 2010 (Cth) for goods purchased in Australia and the Consumer Guarantees Act 1993 (NZ) for goods purchased in New Zealand; and

6) To the fullest extent permitted by law, this warranty supersedes all other warranties attached to the product or its packaging.

7) In the case of services, supplying the services again or the payment of the cost of having the services supplied again, is at the discretion of White International or a 3rd party tribunal elected under the Competition and Consumer Act 2010 (Cth) for goods purchased in Australia and the Consumer Guarantees Act 1993 (NZ) for goods purchased in New Zealand. 8) Our warranty commences from the date of purchase of the above mentioned pumps. Proof of purchase is required before consideration under warranty is given.

*Record your date of purchase in the space below and retain this copy for your records.*

**Date of Purchase** .....**Model Purchased** .....



**[www.whiteint.com.au](http://www.whiteint.com.au)**  
**[www.whiteint.co.nz](http://www.whiteint.co.nz)**

**Please always refer to our website for further technical information & new product innovations**

**Disclaimer:** Every effort has been made to publish the correct information in this manual. No responsibility will be taken for errors, omissions or changes in product specifications.

© 2020 Copyright White International Pty Ltd

TM ® - WARNING: Please be aware that various brands & products depicted within this document are subject to trademark, patent or design registrations. Infringement of any intellectual property contained within this document without express written authority by the appropriate intellectual property holder may result in further legal action to be taken. For any queries regarding use of the contained information please feel free to contact White International Pty Ltd.