

UNIT STARTING AND WORKING

Warning

Never take the electronic board out of the control box.

The wiring diagram inside the terminal block will show you how to correctly wire the controller. Wrong connection will destroy the whole electronic circuit.

Cable used for connection must be a three-wired one with compulsory grounding end. It shall have the outer diameter at 7.5mm min and 8.5mm max. The four screws on the panel board and the two nuts for fixing cable must be well fastened to avoid water entering into the control box and damaging the electronic circuit.

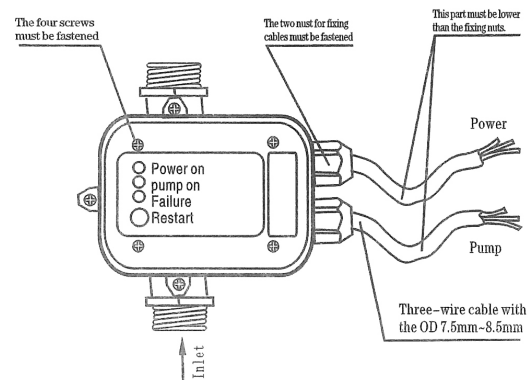

STARTING

When the unit is connected to the electrical network, the green led "Power On" lights up and the yellow led "On" (pump in operation) 2 seconds later indicating that the pump has been started. The pump continues to operate for dozens of seconds enabling the system to fill in the pipes and reach the required pressure.

If this lapse is insufficient, the red led "Failure" lights up. In this event, keep the "Restart" button pressed and wait, with a tap opened, until the red led is off.

Once the button is released the tap is closed, the unit stops the pump at its maximum pressure.

FUNCTIONING

This unit is programmed to perform all the pump control operations automatically.

When breakdowns occur, such as water failure, obstruction of the suction pipe etc., the unit can prevent damages caused by its working in the absence of water.

When there is no water supply to the system, the water pump will stop automatically after 20s running and the red led will glint. The water pump runs automatically for 40s after stopping for 10s and checks the water supply; If there is no water supply, the water pump runs automatically for 40s after stopping for 10s again and checks the water supply; If there is still no water supply, the water pump will stop automatically and turn to the dry - running protection status. After 24 hours, the pump will start automatically and repeat the above procedures. During stopping the pump, the water pump will start automatically if the flow through the controller is more than the starting flow.

Rectification of the failures that have caused the blockage, allows the system to be restarted by pressing the "Restart" button.



AUTO RESTART PUMP CONTROL

ELECTRONIC REGULATOR FOR ELECTRIC PUMPS

WHI-SKI0PP-Y (1.5 bar Start Up)

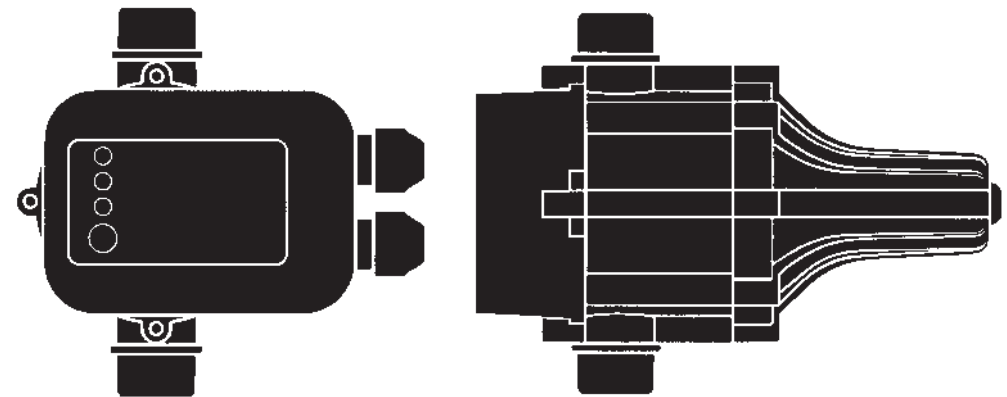

SPECIFICATIONS

Input Voltage 220-240V

Frequency 50/60Hz

Current Max. 10A

Protection Rating IP65

Maximum working pressure 10bar

Max working temperature 60°C

Connection 1" male BSP

INSTRUCTIONS FOR CORRECT UNIT INSTALLATION

If the column of water between the pump and the highest tap exceeds 15m, the unit cannot be installed directly on the pump, but it has to be raised until the column of water between the unit and the highest tap does not exceed 15m.
i.e. If column of water is 20m from the pump, the unit must be placed 5m higher than the pump.

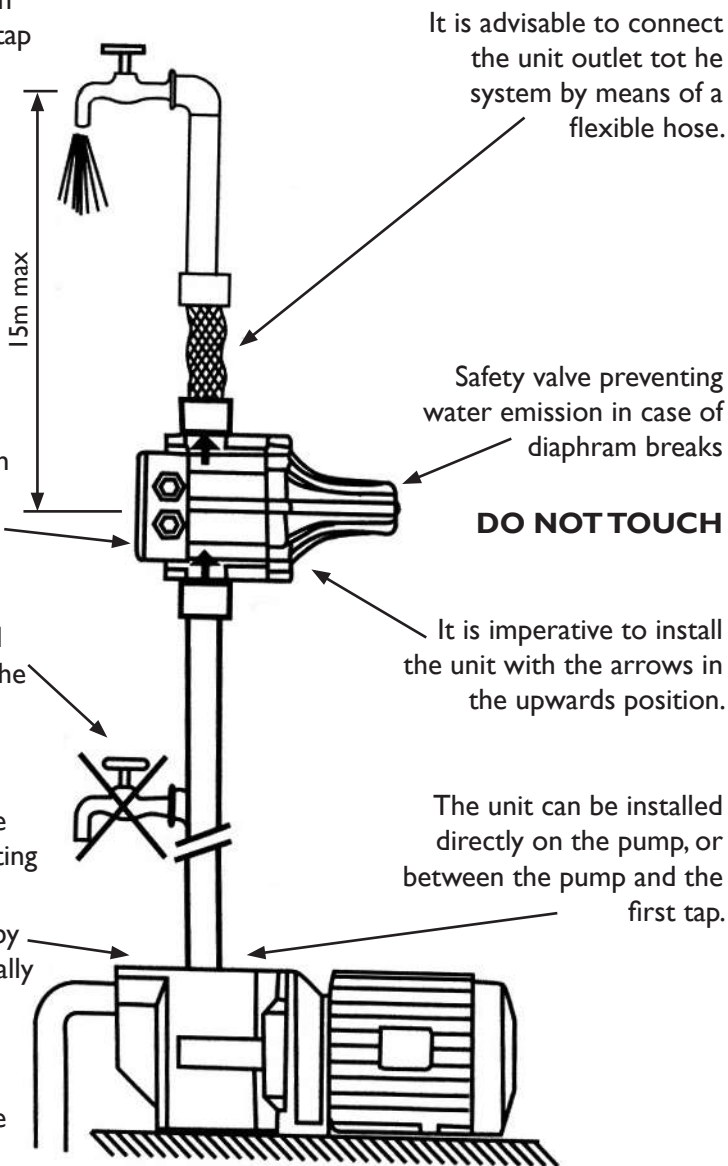

The unit is equipped with a check valve to prevent the pipeline from losing pressure.

NO taps can be installed between the pump and the unit.

PUMP'S PRESSURE

The unit is pre-set by the manufacturer at a restarting pressure of 1.5 bar.

The pressure produced by the pump must be normally 0.8 bar higher than the pre-set pressure.

Before starting the unit check suction and ensure that the pump is primed.

WIRING DIAGRAMS FOR CONNECTING THE UNIT TO DIFFERENT KINDS OF PUMP MOTORS

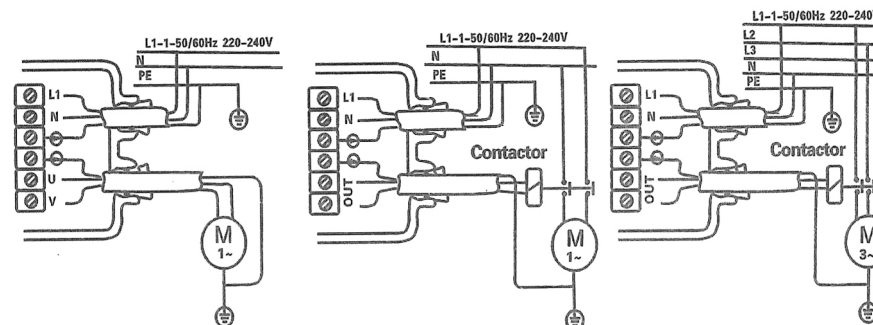

Wiring diagram for connection of single phase 220V pumps up to 1.5kW.

Wiring diagram for connection of single phase 220V pumps over 1.5kW. Through remote control switch.

Wiring diagram for connection of three phase 380V/415V motor pumps through remote control switch.

SPECIFICATIONS FOR REMOTE CONTROL SWITCH

Minimum contacts capacity of 4kW or 5.5HP approx. 220V

| POSSIBLE WORKING DEFECTS | | |
|---------------------------|---|---|
| TYPE OF DEFECT | CAUSES DEPENDING ON THE UNIT | CAUSES NOT DEPENDING ON THE UNIT |
| The pump does not start | The electronic card is broken | Voltage failure Pump jammed Electric cables inverted (line/motor) |
| The pump does not stop | The electronic card is broken The flow detector is blocked in the upper position The reset button is blocked The pump does not provide sufficient pressure | Presence of leaks which are higher than the minimum flow of 0.6 l/min |
| Intermittent pump working | The electronic card is broken The pump does not provide sufficient pressure | Presence of leaks which are lower than the minimum flow of 0.6 l/min |
| The pump is jammed | The electronic card is broken The pump provides a pressure which is lower than the restarting pressure | Water failure Suction problems |