



The pump is a surface mounted pressure system pump supplied ready to install. The unit is ideal for flooded suction and can handle suction lifts to 3m.

The pump is characterised by:

- Includes fully electronic pump controller for automatic pump starting, stopping and restart after power loss and water loss.
- Run dry protection to prevent pump damage
- Automatic electronic control has in-built check valve to prevent water back flow through the pump.
- 2.2bar pump cut in for greater versatility.
- Corrosion resistant pump body, diffuser and impeller to ensure pump durability
- High quality mechanical shaft seal and high quality bearings
- 240V single phase TEFC motor with in-built auto reset thermal overload to prevent the pump from overheating
- AS/NZS4020 Drinking Water Approved

Applications

- Suitable for small scale garden irrigation and tank transfer

Package Information

- 8 kg
- L 400mm x W 235 mm x H 445mm

Liquid:	Electrical data:
Liquid Type: Clean Water Clean water temperature range: 2 – 40°C	Rated voltage: 220 (-6%) -240V (+6%) Mains frequency: 50 Hz P2 (kW): 0.45 (Shaft Power) Current: 4 amps Capacitor: 16 uF Motor duty: Continuous
Materials:	Hydraulic Data:
Pump body, Impeller : Noryl Glass Reinforced Jet/Venturi, Diffuser: Noryl Glass Reinforced Mechanical seal: Carbon/Ceramic/Nitrile O rings: Nitrile Power Cable: 1.5m Cable H05 3G1.0	Max Head: 37m Max Flow: 55 l/min Number taps: 5
Installation:	Ingress protection: IP X4 Insulation class: F
Maximum ambient temperature: 40°C Maximum operating pressure: 6 bar Pipe connections suction/discharge: 1" BSPF / 1" BSPM	

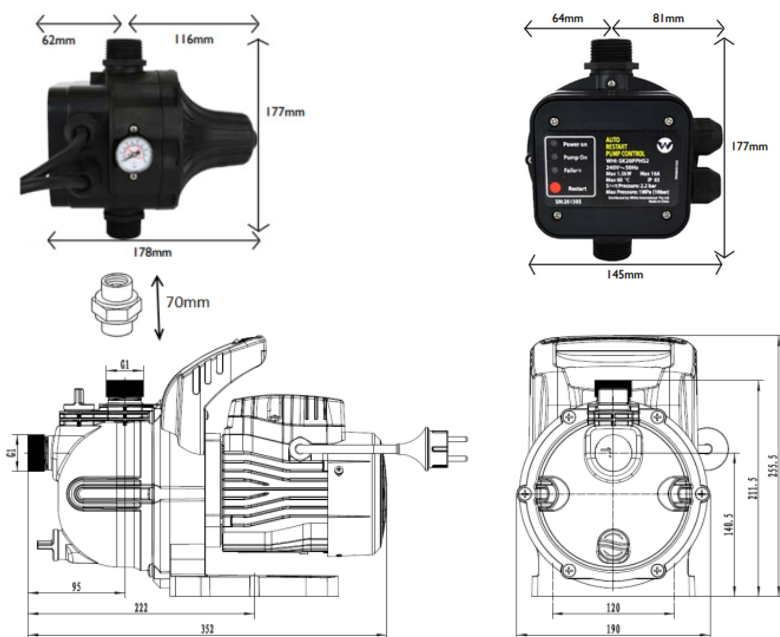

BIA-TECHG60MPCX

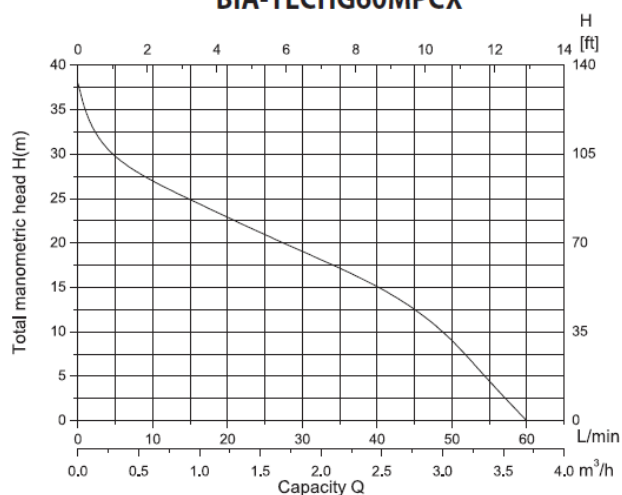

www.whiteint.com.au
www.whiteint.co.nz