

### Bianco RainsaverMK4E Installation and Operating Instructions

Bianco RainsaverMK4E is WaterMark Level 1 approved to ATS5200.477:2006 Certificate No. 23022 and incorporates internal dual check valve back flow prevention for the mains water.



## Bianco Rainsaver MK4E Installation and Operating Instructions

### 1. Introduction:

The **Rainsaver MK4E** is an Automatic Rainwater / Mains Water Changeover Device designed to provide automatic mains back up for Pressure Pump supply systems.

The **Bianco Rainsaver MK4E** is designed to be installed in conjunction with a DAB or Bianco surface mounted or submersible Pressure Pump supply system that is fitted with a **FLOAT SWITCH** (except for the DAB DIVERTRON) as well as an independent **PRESSURE AND FLOW CONTROLLER** with **LOSS OF PRIME PROTECTION** and **AUTOMATIC RE-START**.

**WARNING!** The **Rainsaver MK4E** is **NOT A PUMP CONTROLLER!**

### 2. General Specifications:

Controls pumps to a maximum 1.5 hp, 1.1 kW 240V.  
Maximum water temperature (mains + pump): 40<sup>0</sup> C.  
Maximum recommended continuous pump flow: 100 litres per minute.  
Maximum recommended pump pressure: 800 kPa.  
Maximum recommended mains inlet pressure: 800 kPa.

### 3. Operation:

The **RainsaverMK4E** supplies clean rainwater from a rainwater tank via an automatic pressure system pump to toilets, laundry and garden taps in a household.

Mains water is also connected to the **RainsaverMK4E** as an automatic back up should rain water level be too low, or if there is a power or pump\* failure).

\*Should there be a pump failure, mains back up is achieved by turning the **RainsaverMK4E** off at the power point.

The low voltage float switch supplied prevents the pump from running dry and allows automatic switch over to mains supply should the rain water level in the tank be too low.

### 4. Installation:

#### 4.1 Pump Float Switch installation.

The 10m, 12V DC low voltage float switch supplied, prevents the pump from running dry and allows automatic switch over to mains supply. It is supplied complete with a counterweight and water tank mounting plate, and is designed to enter the rainwater tank from the roof of the rainwater tank.

Choose a location on the roof of the rainwater tank to cut the 85mm hole required. The centre of the hole should be at least 200 mm away from the side of the tank as well as being 200mm away horizontally from tank rainwater entry and rain water tank outlet. Any shavings should be removed with a vacuum cleaner.

Uncoil and lay out the float switch cable. Move the counterweight so that it is **200 mm from the float switch**. Tighten the cable gland on the counterweight to lock it in position.

Position the float switch cable in the water tank mounting plate so that the distance between the mounting plate and the end of the float switch is **100 mm less than the depth of the tank when measured from the float switch access hole**, and tighten the cable gland and conclamp.

Submersible pumps supplied with the **RainsaverMK4E** may have a pump mounted float switch which needs to be cable tied so that it is always in the vertical position.

## 4.2 RainsaverMK4E installation.

The RainsaverMK4E must be mounted in the horizontal position, and the RainsaverMK4E power socket to accept the pump power lead must hang in the down position.

The RainsaverMK4E can be **Wall mounted** or **Pump Mounted** i.e. mounted directly onto a pressure pump outlet. The steel wall mounting bracket, which is connected to your RainsaverMK4E, can be rotated to allow the unit to be wall mounted in either direction, or may be removed for pump mounting.

### 4.21 Wall Mounting:

The RainsaverMK4E can be mounted outdoors on a flat vertical surface.

The RainsaverMK4E can be mounted with the mains inlet pointing in either direction.

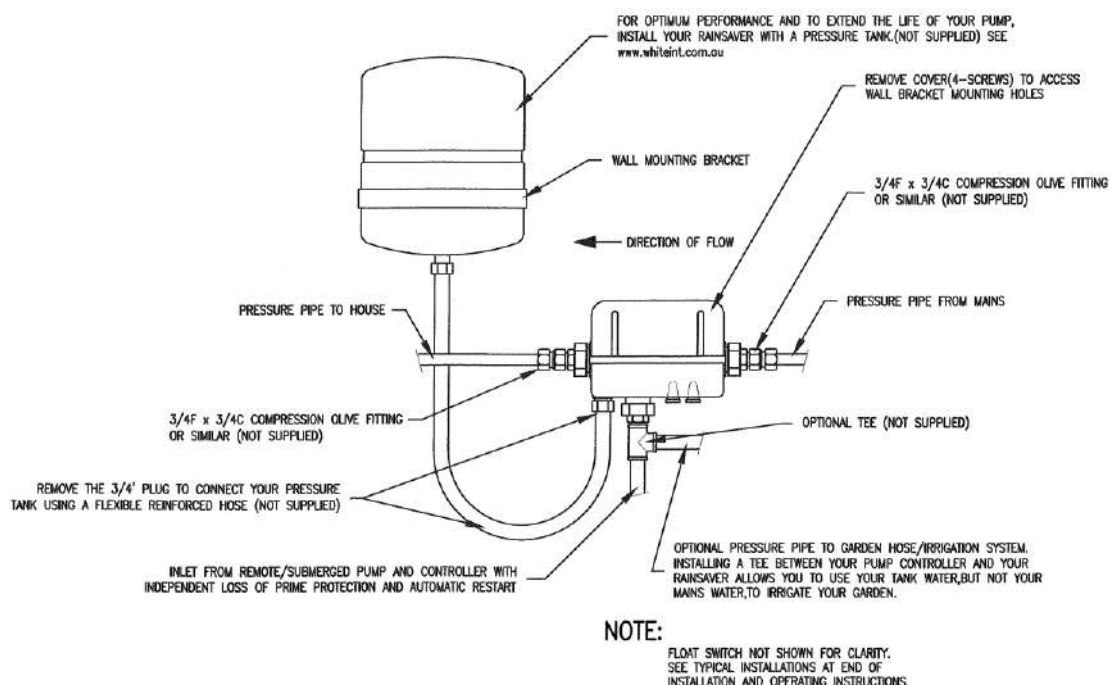

Pressure tank pre-charge pressure should be 65% of pump maximum pressure.

#### Wall Mounting Instructions:

- To reverse the mounting direction, so that "Mains" inlet will be on the left side and "House" outlet on the right, follow the first steps of Pump Mounting Instructions below to remove and reverse the mounting bracket. Then continue:-
- Remove the RainsaverMK4E lid by unscrewing the 4 Phillips head screws
- Hold the RainsaverMK4E in the desired position and mark the screw centres through the keyhole slots in the mounting bracket. Return the RainsaverMK4E to the box.
- Drill and insert mounting hardware into the mounting surface (wall). Insert screws leaving a few millimetres under the head to allow insertion of the mounting bracket
- Mount the RainsaverMK4E onto the screws through the keyhole slots in the mounting bracket. Tighten screws to secure the bracket to the wall
- Replace the RainsaverMK4E lid and re-tighten the four (4) lid screws.

#### 4.22 Pump Mounting:

**RainsaverMK4E** can be mounted directly onto the outlet of the pump with the adaptor supplied. If another size threaded port is found on the pump or controller outlet use quality standard plastic threaded pipe fittings to adapt.

##### Pump Mounting Instructions:

- Remove wall mounting bracket by unscrewing the lower (Pump Inlet) union nut using the plastic spanner provided. Remove the union nut and pipe being careful not to lose any of the internal components.
- Unscrew the two bracket holding screws and remove the bracket.
- REPLACE THE BRACKET HOLDING SCREWS into the housing. This will stop insects creating a nest inside the Rainsaver Unit.
- Replace the lower union nut and pipe being sure that internal components are in place and that the o-ring is properly seated.
- Leave the lower union nut slightly loose to allow fitting and alignment to pump.
- Attach the 3/4" BSPT male pipe fitting to the pump outlet, either directly, or using plastic threaded pipe fittings as required, and tighten using the spanner provided.
- Once the 3/4" BSPT pipe fitting is secured to the pump and the **RainsaverMK4E** aligned as required, tighten the lower nut with the plastic spanner provided.

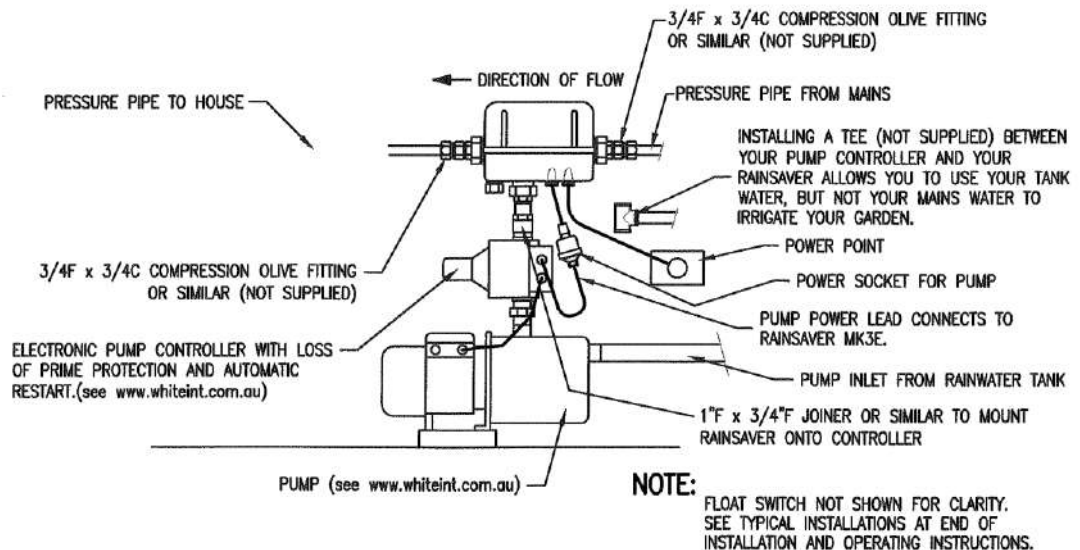

Note: Tank outlet should be 100mm from the bottom of the tank. See ARID handbook.

Note: The female socket from the Rainsaver must hang down.

Note: It is recommended that all surface mounted pumps be protected from the elements.

#### 4.4 Filtration and Water Quality

The **Bianco Rainsaver MK4E** is designed to operate on **clean** rainwater and clean mains water supply, and as such, the rainwater tank should be fitted with an inlet strainer, preferably shaded type to reduce algae, and a suitable first flush device.

White International strongly recommends the use of a strainer or filter upstream with easy access for period cleaning from both the rainwater and mains inlet connections of the **Bianco Rainsaver MK4E**.

Additional water filters may be required. Also check the water tank and first flush diverter as per manufacturers' instructions regarding periodic servicing that is required.

Filters need to be checked regularly as reduced flow caused by blocked filters can damage pumping equipment.

#### 4.5 Plumbing

**Plumbing connections should be carried out by a licensed plumber.**

Use of flexible pipe connections and isolation vales is recommended to assist in alignment and servicing and to reduce any transmitted noise.

Use a standard  $\frac{3}{4}$ " compression x F.I. union or Compression x F.I. elbow fitting to connect between  $\frac{3}{4}$ " copper tubing and  $\frac{3}{4}$ " BSPT threaded pipe fitting at the "MAINS" inlet, "PUMP INLET" (if unit is wall mounted), and "HOUSE" outlets.

Use standard  $\frac{3}{4}$ " BSP female threaded fittings to connect to  $\frac{3}{4}$ " BSPT threaded pipe fitting when connecting other types of piping.

**DO NOT REMOVE THE UNION NUT AND  $\frac{3}{4}$ " BSPT PIPE FITTING AND ATTEMPT TO CONNECT PIPE WORK DIRECTLY TO THE BODY OF THE UNIT!**

**DO NOT ATTEMPT TO CONNECT COPPER OR PLASTIC PIPE, USING COPPER OR NYLON OLIVES, AND COMPRESSION NUT DIRECTLY TO THE  $\frac{3}{4}$ " BSPT PIPE FITTING!**

Always use the spanner provided, or correct open ended spanner, when tightening fittings.

**All pipe-work and outlet fittings from the RainsaverMK4E must be labelled to AS3500.**

The **RainsaverMK4E** control incorporates a dual check valve to prevent cross connection between mains and rainwater. Connection to an underground rain water tank, or local water supply authorities, may require additional, or higher safety level, back flow prevention, and your licensed plumber can advise you on this.

The incorporation of an additional "Tee" fitting between the tank water pressure pump supply, and the **RainsaverMK4E** lower "PUMP INLET", will allow the householder to use collected rainwater, but NOT mains water supply, to irrigate gardens and lawns, or wash cars.

#### 4.6 Pressure Tank Outlet

The **RainsaverMK4E** is supplied with an additional outlet specifically designed for the installation of a pressure tank.

The installation of a pressure tank will:

- Reduce wear and tear on your pump by significantly reducing the number of starts
- Reduce your electricity consumption by significantly reducing the number of starts
- Reduce the incidence of “pressure drop” when opening a tap
- Stop your pump kicking in every time you open a tap or because of a small leak, like a dripping tap, or toilet cistern.

To install a WATERMARK approved pressure tank:

- Turn off both mains water supply pressure and your rainwater tank pump and supply
- Open a tap to remove all pressure from the system
- Using the spanner supplied, remove the ¾” plug from the “AUX. OUTLET” port. Note that there is an o-ring inside the body of the Rainsaver which can be left in place if using a ¾” BSP fitting, or removed if using a ¾” BSPT fitting.
- Use a suitable flexible reinforced hose with ¾” BSP or BSPT MALE THREAD to connect a WATERMARK approved pressure tank such as a **GWS Energy Saver** to your **RainsaverMK4E**.
- **Carefully follow the manufacturer’s instructions regarding pressurization of your pressure tank.**

#### 4.7 Pressure Tank Pre-charge.

To ensure optimum performance and system life, the Pressure Tank pre-charge needs to be set by filling the pressure tank with air through the air valve so that the air pressure is 65% of the pump maximum pressure.

Pre-charge the pressure tank before it is installed by using an air pump or using the local service station facilities.

#### Cautions:

In conjunction with this manual, read and understand the installation and maintenance manual for the water pump that is to be connected to the **RainsaverMK4E**.

The **RainsaverMK4E** and any pump connected to it are not to be used by children or infirm persons and must not be used as a toy.

If the supply cord is damaged, it shall be replaced by the manufacturer or its service agent or similarly qualified person in the order to avoid the hazard.

Mains plug shall be connected in to an appropriated IP rated socket outlet (Note: This requirement is necessary as to meet the requirements of the equipment mounting outdoors)

**A licensed plumber should carry out plumbing connections.**

Servicing of the **RainsaverMK4E** and, or water pump should only be carried out by qualified persons.

Do not clean the **RainsaverMK4E** with abrasive or petroleum based fluids, and do not use hydrocarbon propelled sprays on or around the **RainsaverMK4E**.

## 5. Sound Emissions.

The **RainsaverMK4E** is virtually silent but may emit noises associated with the flow of water through the unit.

In any case, the pump, which is connected to the **RainsaverMK4E**, may emit sound levels, which may inconvenience you or your neighbours, or may operate during normal sleeping hours, which may be prohibited by local government regulations. If this is the case, your **RainsaverMK3** can be switched off during the night or may be operated from a time clock. Your **RainsaverMK4E** will automatically supply your house with Mains water supply while the pump is inactive.

## 6. Maintenance.

Ensure that water flowing through the **Rainsaver MK4E** is as free from dirt and foreign matter as conditions allow.

Ease of accessibility will aid any maintenance and reduce any servicing costs if required.

Periodically inspect the rainwater tank inlet strainer and the first flush device. Periodically inspect filters downstream and strainers if fitted upstream from the **Bianco Rainsaver MK4E** every 6 months depending on water quality and usage.

Operate the Rainsaver on mains regularly or at least once a month by turning the power off to the **RainsaverMK4E**.

## 7. Trouble shooting.

Consult the manuals supplied with the water pump and its controller if fitted in addition to the following guide.

1. Mains flow is not available or low when Pump is switched off or not operating.
  - a. Isolation valve, if fitted, is not open.
  - b. Debris has jammed the mains inlet check valve closed.
  - c. External Inlet strainer / filter, if fitted, are blocked.
2. Pump flow is not available or low when pump is operating through Bianco Rainsaver MK4E.
  - a. Pump has lost its prime.
  - b. Isolation valve, if fitted, is not open.
  - c. Debris has jammed the pump inlet check valve closed, or has blocked the check valve.
  - d. External Inlet strainer / filter, if fitted, is blocked.
3. Pump does not start.
  - a. Rainwater tank is empty.
  - b. Power supply is off.
  - c. Float switch is not installed correctly.
  - d. Pump controller is not installed correctly or jammed with debris.
  - e. Pump has a fault.
4. Pump does not stop.
  - a. Leak in plumbing.
  - b. Pump controller is not installed correctly or jammed with debris
  - c. Float switch is not installed correctly.

Note\* Should there be a pump failure, mains back up is achieved by turning the **RainsaverMK4E** off at the power point.

For after sales service please contact White International Customer Service: 1300 783 601.

## **8. Pumps**

Pumps and pump controllers must be accessible and fitted with barrel unions for service and maintenance.

It is recommended that all surface mounted pumps be protected from the elements with a suitable pump cover.

Submersible pump accessories such as pump stands, high inlets, floating suction hose kits assist in the pumping cleaner water that is found at higher levels in the rainwater tank.

See pump installation accessories on page 13.

## **9. Water Tanks**

Water borne algae and roof litter can accumulate at the bottom of your rainwater tank that can be sucked up by your pump. To reduce filter blockages we recommend that suction outlets on rainwater tanks be 100 mm from the bottom of the tank (see page 10), and submersible pumps elevated by 90 mm (see pages 10,11).



Installation Dimensions

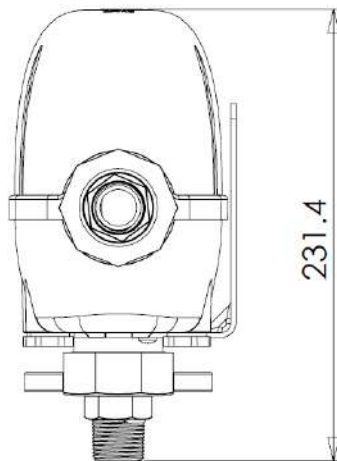
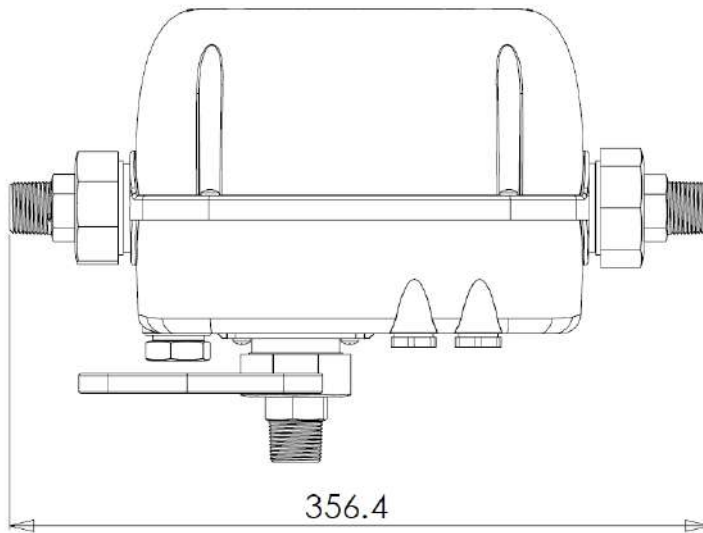
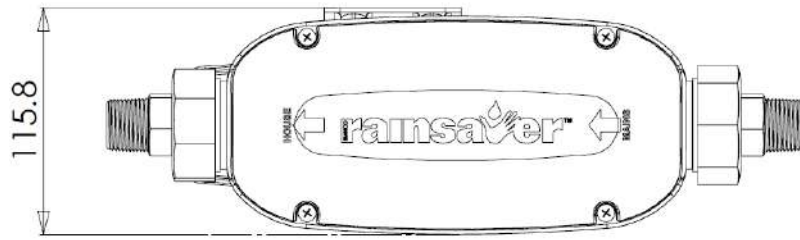

Typical Installations.

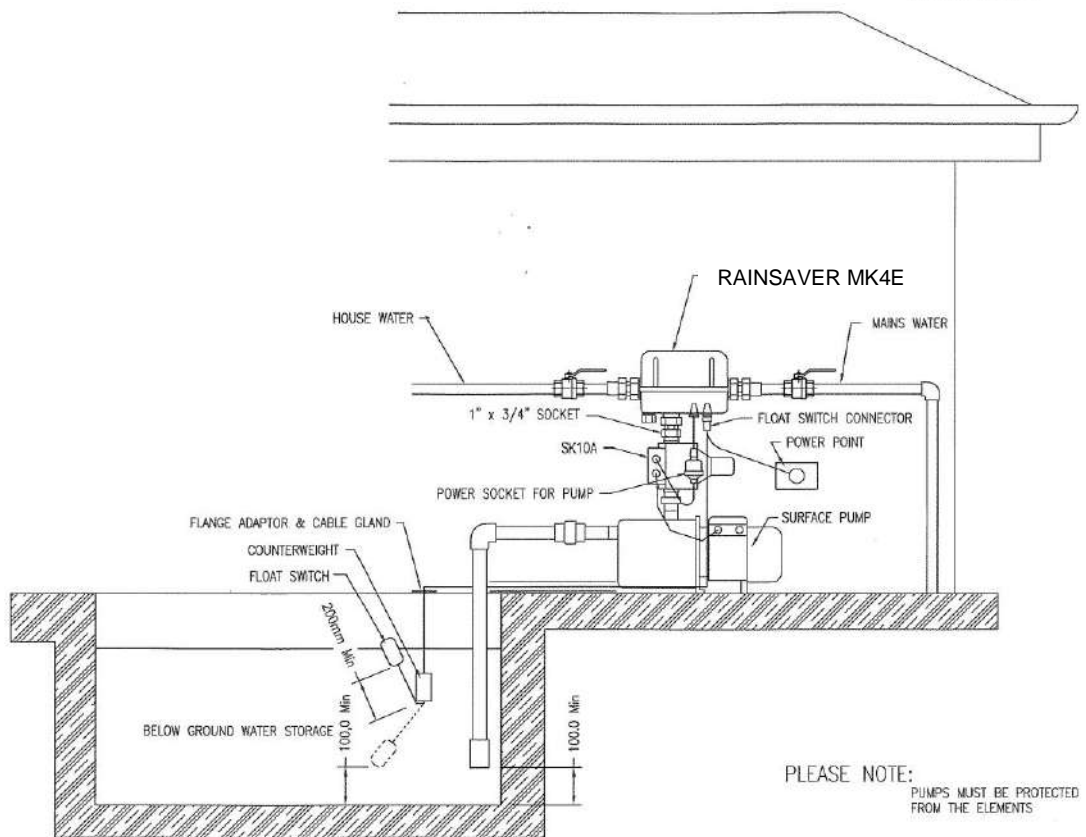
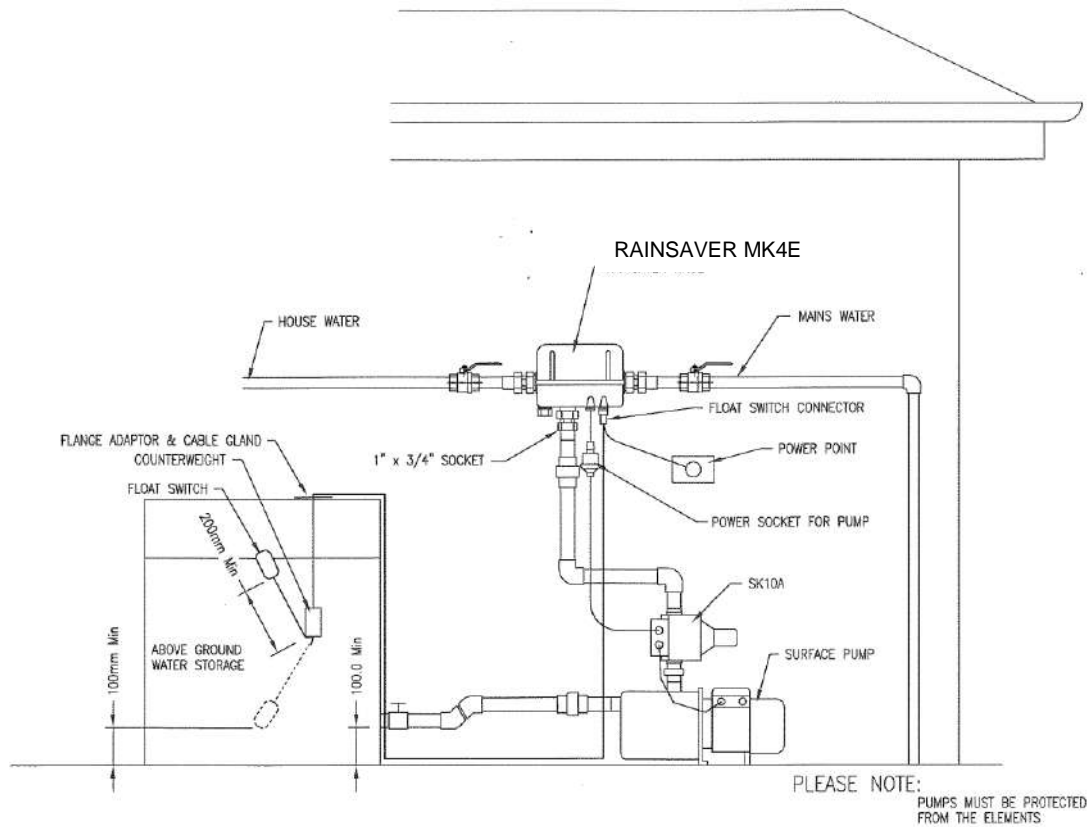

DAB or BIANCO surface mounted pumps.

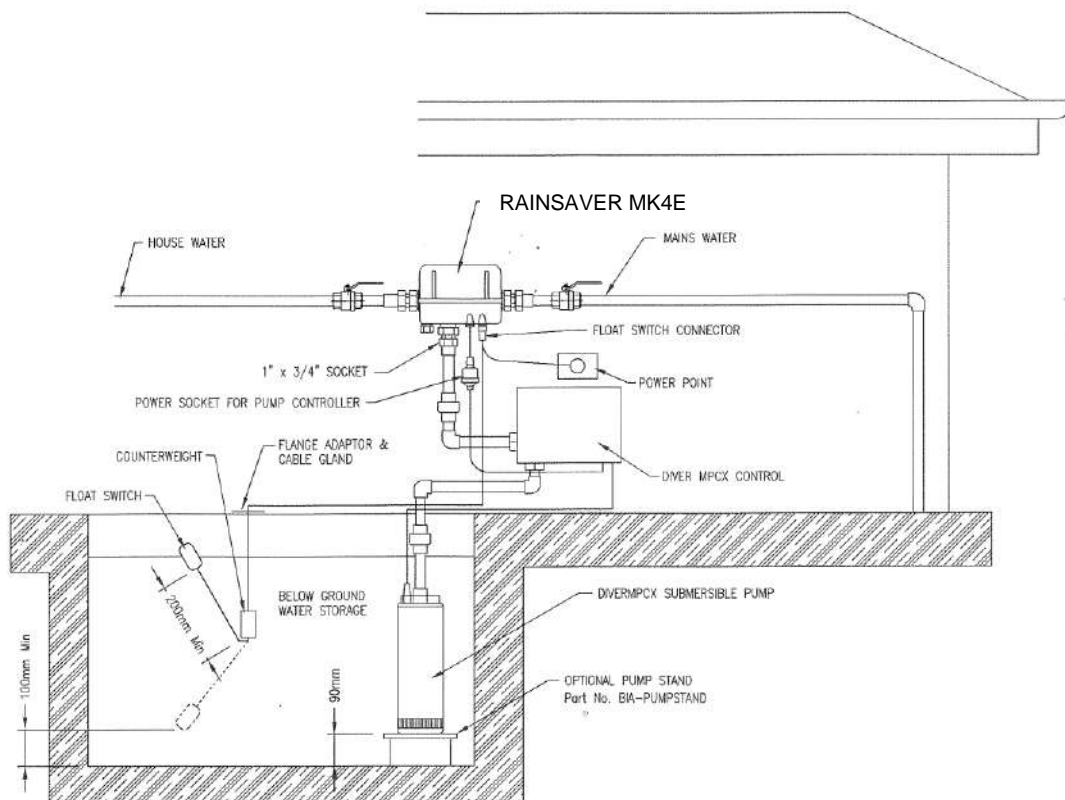
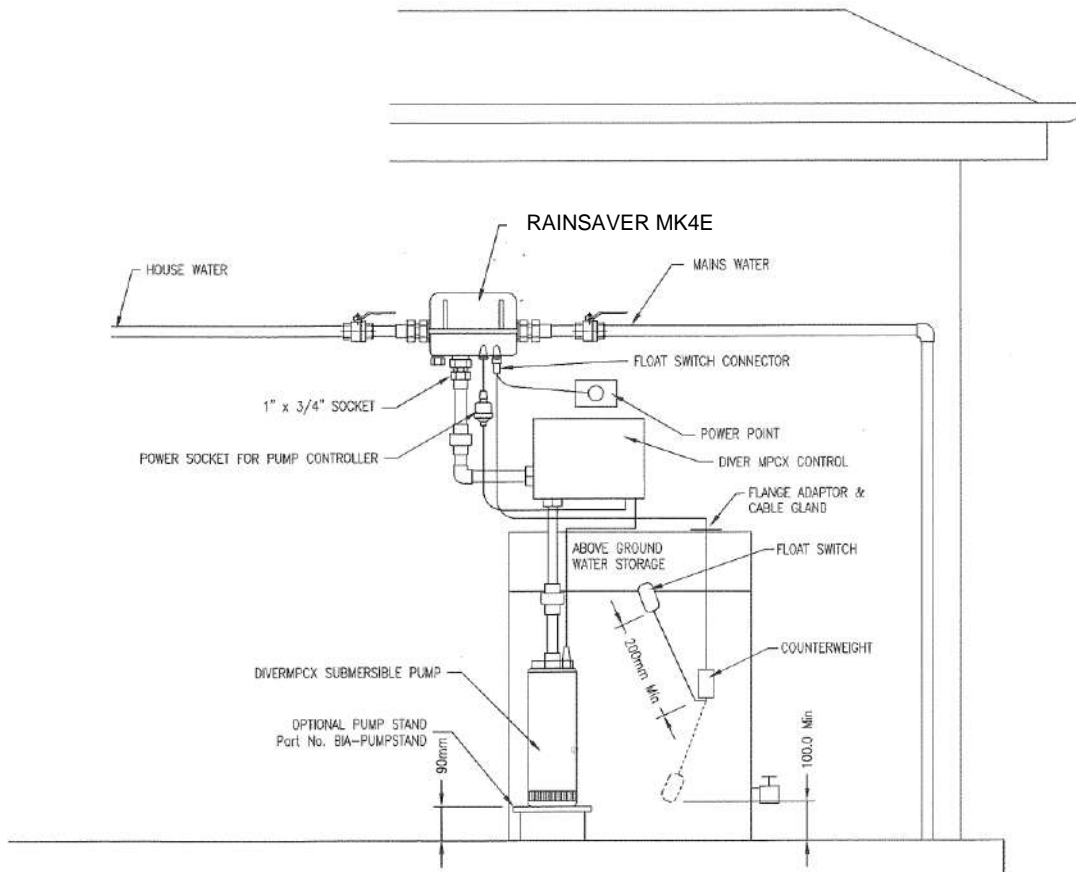

TESLA DIVERxxxMPCX Submersible Pump

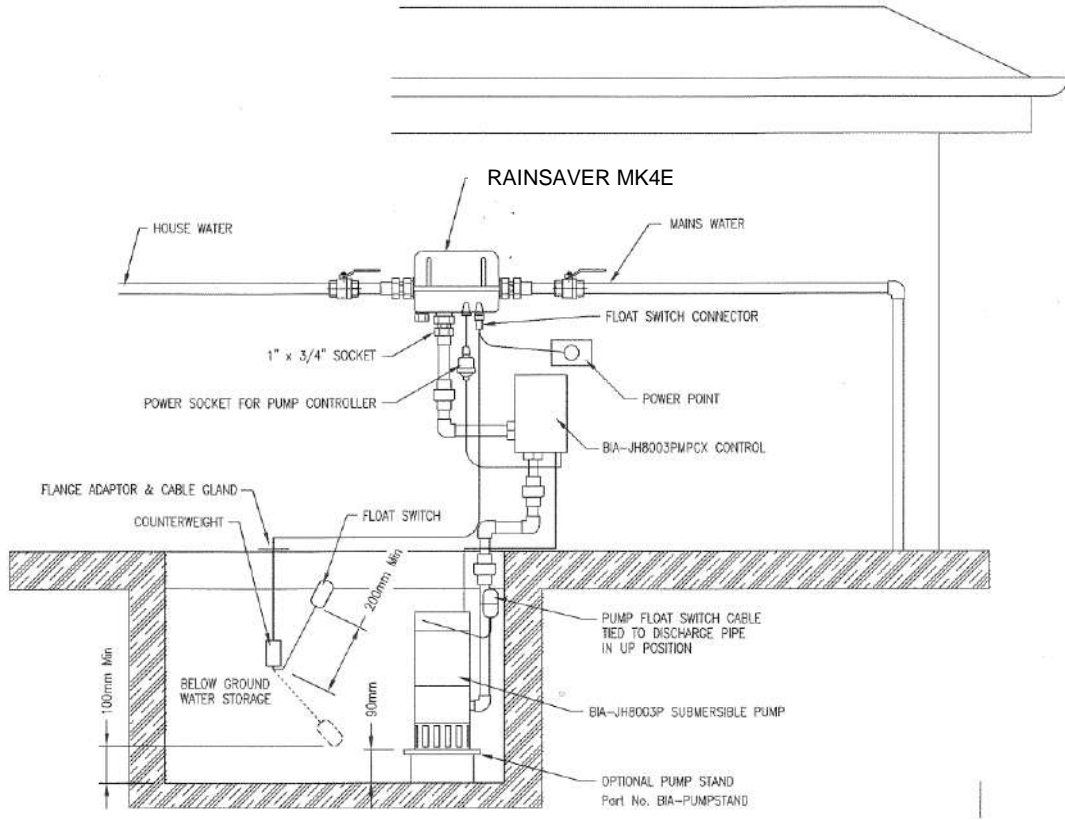
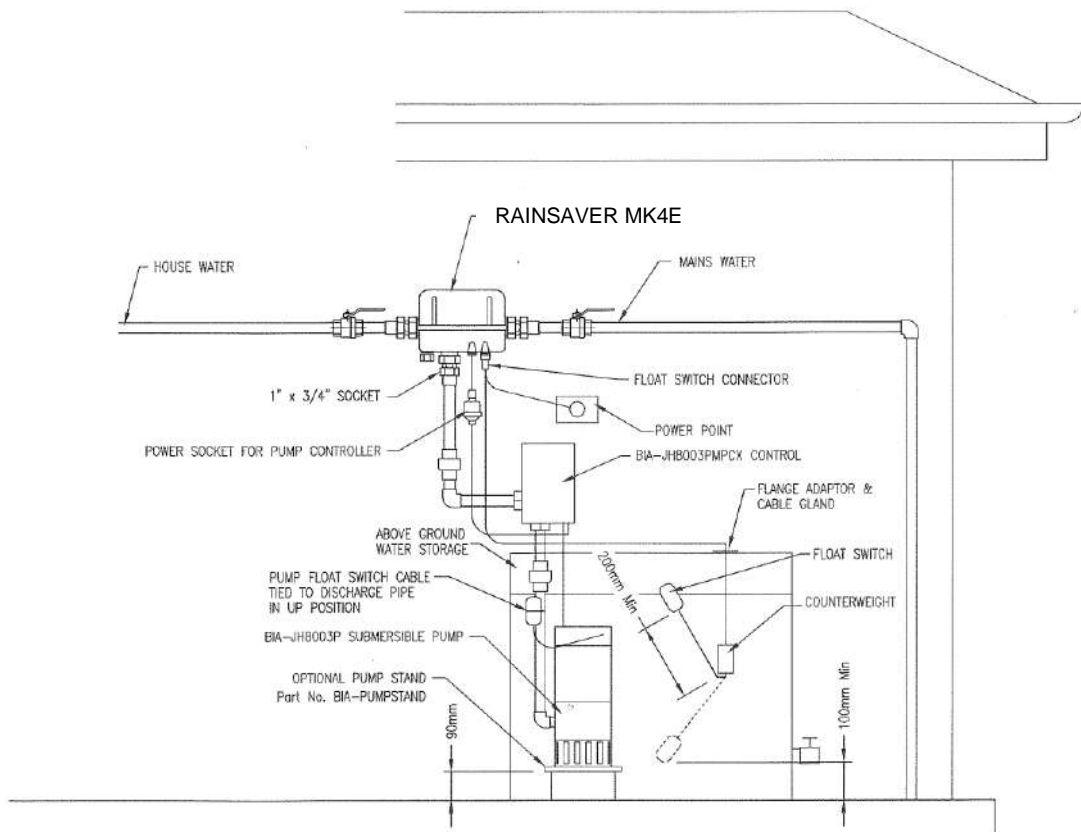

**BIANCO JH8003PMPX or B42A Submersible Pumps**

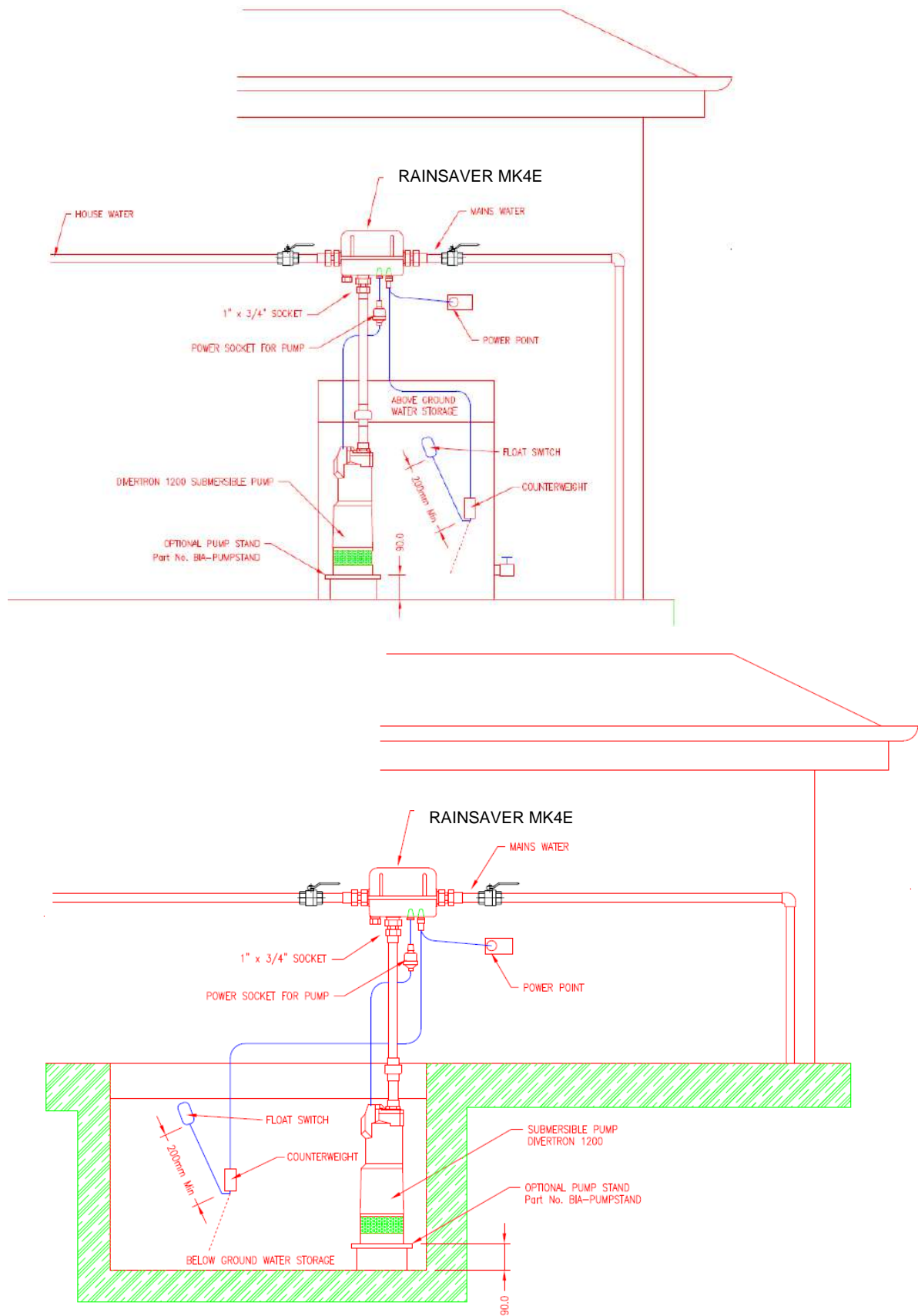

DAB DIVERTRON1200 Submersible Pump

## Accessories



Pump Cover protects pump from the elements.



Pump stand for submersible pumps lifts pump up to pump cleaner water.



DAB Divertron X conversion kit allows pumping from higher level and connection to floating suction kits to pump cleaner water higher in the tank.

## Accessories



Tesla DiverDry conversion kit allows pumping from higher level and connection to floating suction kits to pump cleaner water.



Floating suction hose kits allow pumping from cleaner water higher in the tank.



Float switch for bladder tank.



Piggy back float switch option for Divertron.



## RAINSAVER MK4E 2 YEAR INFIELD WARRANTY

### Terms & Conditions

This warranty is given in addition to the consumer guarantees found in the Competition and Consumer Act 2010 (Cth) for goods purchased in Australia and the Consumer Guarantees Act 1993 (NZ) for goods purchased in New Zealand:

- 1) White International Pty Ltd / White International NZ Ltd warrants that the Bianco RAINSAVER MK4E controls that we distribute, are free from defects in workmanship and materials, for 2 years from the date of purchase. Subject to our conditions of warranty, White International will repair any defective products free of charge on site within 25 kilometres of our nearest authorized in-field Bianco RAINSAVER Service Agent. In the event that service is required outside the 25 km radius of the nearest in-field Bianco RAINSAVER Service Agent, arrangements for the payment of additional travel may be incurred between the "owner" and the "service agent" before work is carried out. If you believe that you have purchased a defective product and wish to make a claim under this warranty, contact us on our Sales Hotline on 1300 783 601, or send your claim to our postal address or faxline below and we will advise you as to how next to proceed. You will be required to supply a copy of your proof of purchase to make a claim under this warranty.
- 2) The warranty includes in field labour costs where the Bianco RAINSAVER MK4E packaged including a pump is installed within a 25 km radius of an authorised in-field Bianco RAINSAVER Service Agent. This warranty excludes transportation costs to and from White International or its appointed service agents, defects due to non-compliance with installation instructions, neglect or misuse, inadequate protection against the elements, low voltage or use or operation for purposes other than those for which they were designed or where equipment is not readily accessible. For further information regarding the suitability of your intended application contact us on our Sales Hotline on 1300 783 601. White International will not bear the costs of an invalid claim under this warranty.
- 3) The 2 Year Warranty refers to Bianco RAINSAVER MK4E controls after the 1<sup>st</sup> May 2015, and is not transferable to another Bianco Rainsaver product and only applies to the original owner, purchaser or end user, and is in addition to the consumer guarantees found within the Competition and Consumer Act 2010 (Cth) for goods purchased in Australia and the Consumer Guarantees Act 1993 (NZ) for goods purchased in New Zealand.
- 4) Our goods come with guarantees that cannot be excluded under the Australian Consumer Law. You are entitled to a replacement or refund for a major failure and for compensation for any other reasonably foreseeable loss or damage. You are also entitled to have the goods repaired or replaced if the goods fail to be of acceptable quality and the failure does not amount to a major failure.
- 5) To the fullest extent permitted by law, White International excludes its liability for all other conditions or warranties which would or might otherwise be implied at law. To the fullest extent permitted by law, White International's liability under this warranty and any other conditions, guarantees or warranties at law that cannot be excluded, including those in the Competition and Consumer Act 2010 (Cth), is expressly limited to:
  - (a) in the case of products, the replacement of the product or the supply of equivalent product, the payment of the cost of replacing the product or of acquiring an equivalent product or the repair of the product or payment of the cost of having the product repaired, is at the discretion of White International or a 3<sup>rd</sup> party tribunal elected under the Competition and Consumer Act 2010 (Cth) for goods purchased in Australia and the Consumer Guarantees Act 1993 (NZ) for goods purchased in New Zealand; and
- 6) Our warranty commences from the date of purchase of the above mentioned product. Proof of purchase is required before consideration under warranty is given. Record your date of purchase in the space below and retain this copy for your records.

Date of Purchase ..... Model Purchased .....



**WHITE INTERNATIONAL PTY LTD**  
ABN 48 000119380  
52-60 Ashford Ave, MILPERRA NSW 2214  
PO BOX 304, MILPERRA LPO NSW 2214  
Ph: 02 9783 6000 Fax: 02 9783 6001  
Customer Service Hotline: 1300 783 601  
Customer Service Faxline: 02 9783 6003  
EMAIL: Sales Enquiries: [info@whiteint.com.au](mailto:info@whiteint.com.au)

**WHITE INTERNATIONAL NZ LTD**  
15G Kerwyn Ave, EAST TAMAKI, AUCKLAND NZ  
PO BOX 12704, PENROSE, AUCKLAND  
Ph: 09 579 977 Fax: 09 579 7775  
Customer Service Hotline: 0800 509 506  
Customer Service Faxline: 0800 804 344  
EMAIL: General Info Enquiries: [sales@whiteint.co.nz](mailto:sales@whiteint.co.nz)